

2017 | 2018
Catalogue | Catálogo | Catalogue

Grok

2 We create spaces and sensations through light.

Grok embodies a way of understanding and interacting with one another that is based on intuition and empathy. It is our soul and these are our values. This is how we act and how we interact with our clients and employees.

Grok evoca una forma de entenderse y relacionarse mediante la intuición y la empatía. Es nuestra esencia y son nuestros valores. Y así es como actuamos y nos relacionamos con nuestros clientes y colaboradores.

La marque Grok évoque une façon de communiquer et de nouer des liens à travers l'intuition et l'empathie. Elle représente notre essence et nos valeurs. C'est la base de nos actions et de nos relations avec clients et collaborateurs.

When we created Grok in 1998, we made a commitment to a contemporary product line that would decorate and build spaces through attractive design and interaction between their light and the ambient light. We believe there is a light and a luminaire perfectly suited to each room, each activity and each individual.

Light is emotion. It has the ability to influence our physical and emotional comfort. Hence, designing the right luminaire and evoking the feelings that its light will stir in the lives of all our clients is absolutely fundamental.

The emergence of led technology in the world of lighting has brought about a revolution. At Grok, we select first-class diodes from the best manufacturers around the world because their high chromatic performance offers sharper, more intense, purer and deeper colours. However, they also offer longer service life, reduced consumption, increased environmental protection, greater light efficiency, bigger savings and, above all, complete versatility. They provide us with a great opportunity to offer more and better quality light in the projects undertaken by our clients.

We look for innovative concepts, ideas and directions to create singular pieces with personality for our clients' spaces. And we work together with all our employees to achieve perfection in everything we do. No aspect of the design or material quality is left to chance.

Grok forms part of the LEDS-C4 group, which has been designing and producing lighting products for interior and exterior design projects for over 40 years. More than four decades of innovation to offer the best services and light quality on all projects.

At LEDS-C4, we are a team of over 330 professionals who strongly believe in excellence and have a passion for our work. We believe in maintaining close ties with our clients, collaboration, responsibility and sustainability. We share and apply these values to everything we do. These values have led us to become an international benchmark with operations in over 140 countries and a range of over 3,500 products; over 3,500 different lighting sensations.

We create spaces and sensations through light.

Cuando en 1998 creamos Grok, apostamos por una línea de producto contemporáneo que, a través de su diseño atractivo y de la interacción de su luz con la luz ambiente, decorara y construyera espacios. Porque existe una luz y una luminaria apropiada para cada estancia, para cada actividad, para cada persona.

La luz es emoción. Tiene la capacidad de influir en nuestro confort físico y emocional. Por eso, diseñar la luminaria adecuada y la sensación que su luz producirá sobre la vida de cada uno de nuestros clientes es primordial.

La introducción del led en el mundo de la iluminación ha supuesto una revolución. En Grok seleccionamos diodos de primera calidad, de los mejores productores mundiales porque su alto rendimiento cromático nos ofrece colores más nítidos, intensos, puros y profundos. Pero también una mayor vida útil, menor consumo, mayor protección del medio ambiente, mayor eficiencia luminosa, mayor ahorro y, sobre todo, una total versatilidad. Una gran oportunidad para ofrecer más y mejor calidad de luz en los proyectos de nuestros clientes.

Buscamos conceptos, ideas y tendencias innovadoras para crear piezas singulares para espacios y clientes con personalidad. Y trabajamos conjuntamente con todos nuestros colaboradores para conseguir la perfección en todo lo que hacemos. Sin dejar al azar ningún detalle en el diseño o en la calidad de los materiales.

Grok forma parte del grupo LEDS-C4 que, desde hace más de 40 años, diseña y produce piezas de iluminación para proyectos de interior y exterior. Más de cuatro décadas innovando para ofrecer el mejor servicio y la mejor calidad de la luz en todos los proyectos.

En LEDS-C4 somos más de 330 profesionales que creemos en la excelencia, en la pasión por nuestro trabajo, en la proximidad, en la colaboración, en la responsabilidad y en la sostenibilidad. Valores que compartimos y que ponemos en práctica en todo lo que hacemos. Unos valores que nos han llevado a ser un referente internacional presente en más de 140 países con una oferta de más de 3.500 productos, más de 3.500 sensaciones lumínicas diferentes.

Creamos espacios y sensaciones a través de la luz.

Lorsque nous avons créé Grok, en 1998, nous avons misé sur une ligne de produits contemporains capables de décorer et de structurer l'espace grâce à un design attractif et à l'interaction de l'éclairage avec la lumière ambiante. Parce qu'il existe une lumière et un luminaire adaptés à chaque espace, à chaque activité, à chaque personne.

La lumière est émotion. Elle a la capacité d'influer sur notre confort physique et émotionnel. Pour cette raison, il est primordial de bien concevoir le luminaire et la sensation que sa lumière produira sur la vie de chacun de nos clients.

L'arrivée des lampes led dans le monde de l'éclairage a constitué une révolution. Avec Grok, nous sélectionnons des diodes de qualité supérieure fabriquées par les meilleurs producteurs mondiaux, parce que leur rendement chromatique élevé offre des couleurs plus nettes, plus intenses, plus pures et plus profondes. Mais aussi une durée de vie accrue, une consommation réduite, une plus grande protection de l'environnement, une efficacité lumineuse renforcée, plus d'économies et, surtout, une polyvalence totale. Tout cela nous permet de proposer davantage de lumière de meilleure qualité dans tous les projets de nos clients.

Nous recherchons des idées, des tendances et des concepts innovants pour créer des pièces singulières destinées aux espaces et aux clients exigeants. Nous travaillons aux côtés de tous nos collaborateurs pour obtenir la perfection dans tout ce que nous faisons. Sans laisser le moindre détail au hasard en termes de design ou de qualité des matériaux.

Grok fait partie du groupe LEDS-C4 qui, depuis plus de 40 ans, conçoit et produit des luminaires destinés à des projets d'intérieur et d'extérieur. Plus de quatre décennies d'innovation pour offrir un service et une qualité de lumière irréprochables à tous les niveaux.

LEDS-C4 réunit plus de 330 professionnels qui croient en l'excellence, en la passion du travail bien fait, en la proximité, en la collaboration, en la responsabilité et en la durabilité. Des valeurs que nous partageons et que nous mettons en pratique dans tout ce que nous faisons. Des valeurs qui ont fait de nous une référence internationale, présente dans plus de 140 pays avec une offre supérieure à 3 500 produits et à 3 500 sensations lumineuses différentes.

Nous créons espaces et sensations à travers la lumière.

Grok, light is life.

Designers

The vision of our designers.
La visión de nuestros diseñadores.
La vision de nos designers.



Benedito Design

“The use of beauty.”
“La utilidad de la belleza.”
“L'utilité de la beauté.”

Estudi Ribaudí



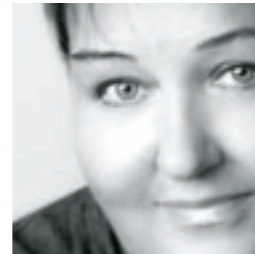
“We beautify and simplify our surroundings to improve the everyday life.”
“Embellecemos y simplificamos nuestro entorno para mejorar el día a día.”
“Nous embellissons et simplifions notre décor pour améliorer le quotidien.”



Francesc Vilaró

“Moulding the light allows us to design the context creating unique spaces and environments.”
“Modelar la luz nos permite diseñar el contexto creando espacios y ambientes únicos.”
“Modeler la lumière nous permet de dresser le décor en créant des espaces et des ambiances uniques.”

Gemma Bernal



“As a designer I tend to propose useful, simple and warm objects.”
“Como diseñadora trato de proponer objetos útiles, simples y amables.”
“En tant que designer, je m'attache à proposer des objets qui joignent l'utile à l'agréable en toute simplicité.”

Jordi Llopis



“The power of the look to become real objects.”
“La fuerza de la mirada para convertirla en objetos reales.”
“La force du regard pour transformer la lumière en objets réels.”

Josep Patsí



“When art and technique come together.”
“Cuando arte y técnica se encuentran.”
“La rencontre de l'art et de la technologie.”

Nahtrang Disseny

“Working with light is a challenge. Obtaining a great result is magic.”
“Trabajar la luz es un reto. Obtener un buen resultado es mágico.”
“Travailler la lumière est un défi. Obtenir un bon résultat est magique.”



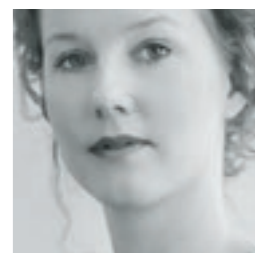
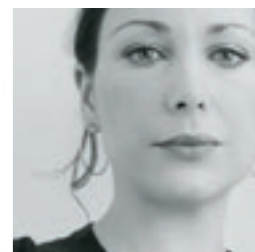
Ramón Valls



“A little bit more is always possible.”
“Un poco más casi siempre es posible.”
“Un petit plus est presque toujours possible.”

WIS Design

“Wisdom and poetry for everyday objects.”
“Sabiduría y poesía para los objetos cotidianos.”
“Sagesse et poésie pour les objets du quotidien.”

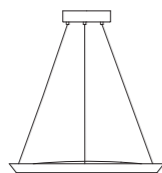


Index

Pendant
Suspensión
Suspension

1.

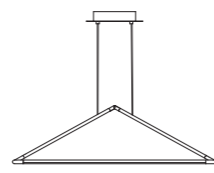
Saturn
26



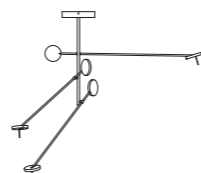
Candle
32



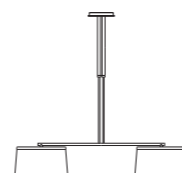
Tubs
42



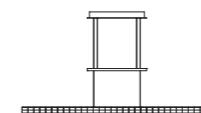
Invisible
48



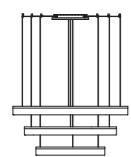
Leila
128



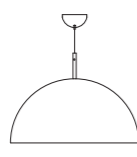
Stream
130



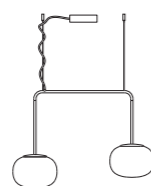
Circ
56



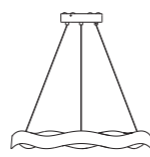
Umbrella
68



Alive
72



Hello
78



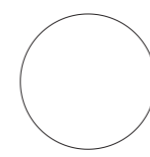
Talk
82



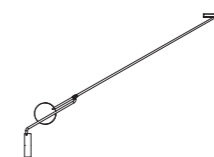
Wall
Pared
Mural

2.

Prime
134



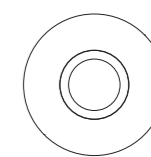
Invisible
140



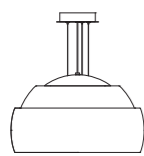
Flavia
144



Big Bang
148



Balloons
86



Bamboo
89



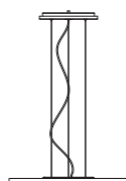
Clear
92



Emy
95



Net
98



Bend
152



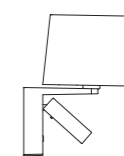
Rizz
156



Eos
160



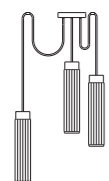
Hall
164



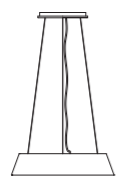
Surf
168



Rigatto
103



Ringofire
106



Angie
110



Aura
112



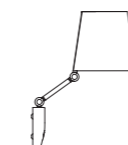
Blomma
115



Talk
172



Emy
175



Igloo
178



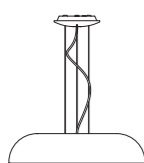
Skata
180



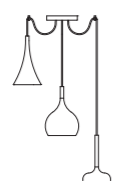
Suite
182



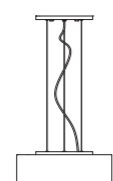
Tandem
118



Sixties
120



Spin
122



Tulip
124



Twins
126



Stream
184



Wave
186

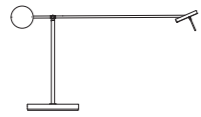


Flat
188

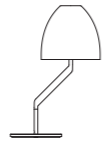


Table
Sobremesa
Table
3.

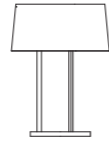
Invisible
192



Flavia
196



Premium
200



Hall
204



Medusa
208



Talk
210

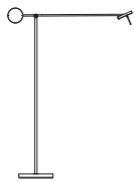


Emy
212



Floor
Pie
Pied
4.

Invisible
216



Flavia
220



Premium
224



Hall
228



Medusa
231



Emy
234



Bamboo
237



Leila
240



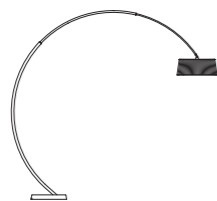
Circ
242



Bosquet
245

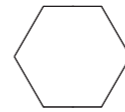


Hoop
248

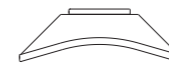


Ceiling
Techo
Plafond
5.

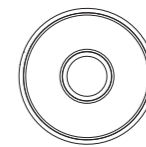
Six
252



Igloo
255



Spin
258



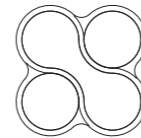
Circ
260



Net
262



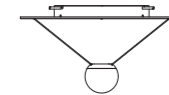
Ocho
264



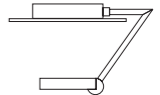
Tandem
266



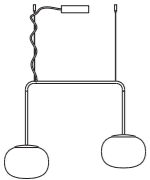

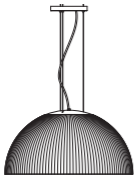
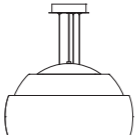


Single
268

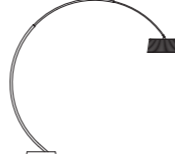
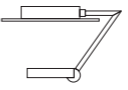

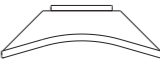


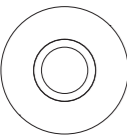





Ibis
270

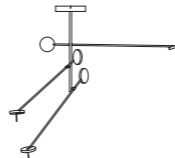


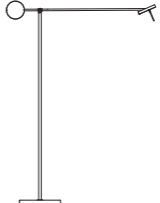
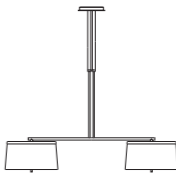










Collections index



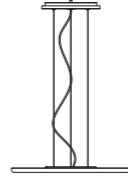

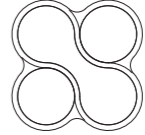
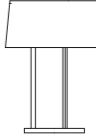
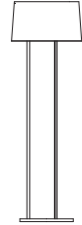
Alive 72 	Angie 110 	Aura 112 	Balloons 86 	Bamboo 89 	Bend 237 152 
---	--	---	--	--	--

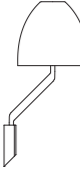


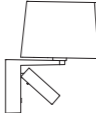


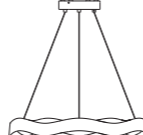
Hoop 248 	Ibis 270 	Igloo 178 255 	
---	---	---	---

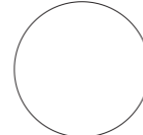
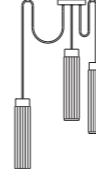


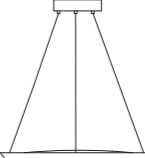
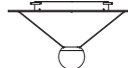
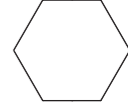
Big Bang 148 	Blomma 115 	Bosquet 245 	Candle 32 	Circ 56 242 260 	
---	---	--	--	--	---

Invisible 48 	140 	192 	216 	Leila 128 240 	
---	--	--	--	---	---

Clear 92 	Emy 95 	175 	212 	234 	Eos 160 	Flat 188 
---	---	--	--	--	--	---

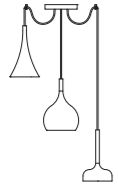
Medusa 208 	231 	Net 98 262 		Ocho 264 	Premium 200 224 	
---	--	--	---	---	---	---

Flavia 144 	196 	220 	Hall 164 204 		228 	Hello 78 
---	--	--	--	---	--	---

Prime 134 	Rigatto 103 	Ringofire 106 	Rizz 156 	Saturn 26 	Single 268 	Six 252 
--	--	--	---	--	---	--

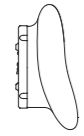
Sixties

120



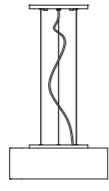
Skata

180

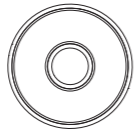


Spin

122

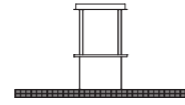


258



Stream

130



184



Suite

182



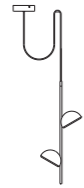
Surf

168



Talk

82



172

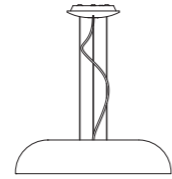


210



Tandem

118

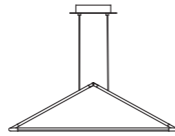


266



Tubs

42



Tulip

124



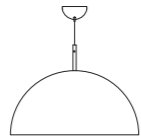
Twins

126



Umbrella

68



Wave

186





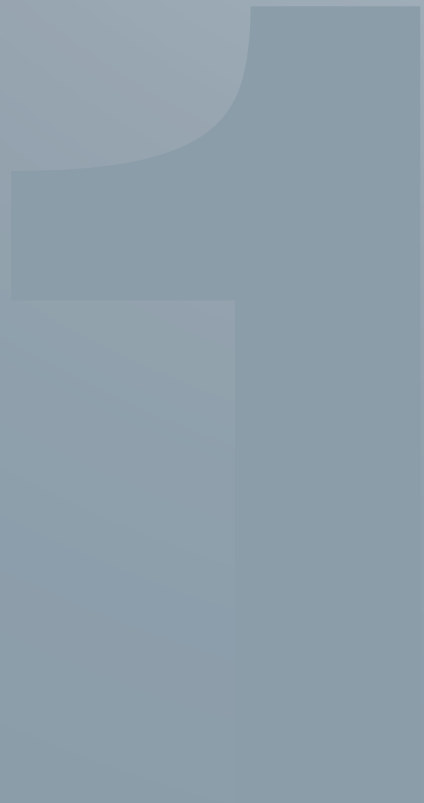
Grok



Light is life.







Pendant
Suspensión
Suspension

Saturn	26
Candle	32
Tubs	42
Invisible	48
Circ	56
Umbrella	68
Alive	72
Hello	78
Talk	82
Balloons	86
Bamboo	89
Clear	92
Emy	95
Net	98
Rigatto	103
Ringofire	106
Angie	110
Aura	112
Blomma	115
Tandem	118
Sixties	120
Spin	122
Tulip	124
Twins	126
Leila	128
Stream	130



Benedito Design

Saturn





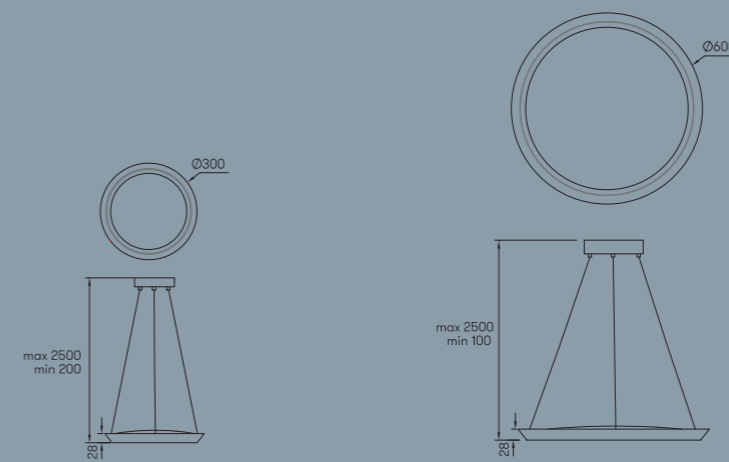


Saturn

Serenity. This next-generation lamp's hallmark is its purity, simplicity and the timelessness of its lines. Each of its characteristics has been included to add a specific value.

Serenidad. La seña de identidad de esta lámpara de última generación se encuentra en la pureza, sencillez y atemporalidad de sus líneas. Cada uno de sus detalles han sido incorporados para ofrecer un valor determinado.

Sérénité. La caractéristique de cette lampe dernière génération se trouve dans la pureté, la simplicité et l'intemporalité de ses lignes. Chaque détail a été intégré pour apporter une certaine valeur.



00-6015-06-M1 (Mains dimming)* 

LED 13W A++ A
1300 lm 2700K

00-6014-06-M1 (Mains dimming)* 

LED 40W A++ A
4000 lm 2700K



* Mains dimmer compatibility at www.leds.c4.com (Products & Downloads)

* Compatibilidad con reguladores corte de fase en www.leds-c4.com (Productos & Descargas)

* Compatible avec des variateurs en coupure de phase que vous pouvez consulter www.leds-c4.com (Produits & Téléchargements)



Finishing | Acabados | Finitions

 06 Copper | Cobre | Cuivre

Materials | Materiales | Matériaux

PS Diffuser material polystyrene | Material difusor Poliestireno | Matériau diffusant Polystyrène

ST Steel | Acero | Acier



Benedito Design

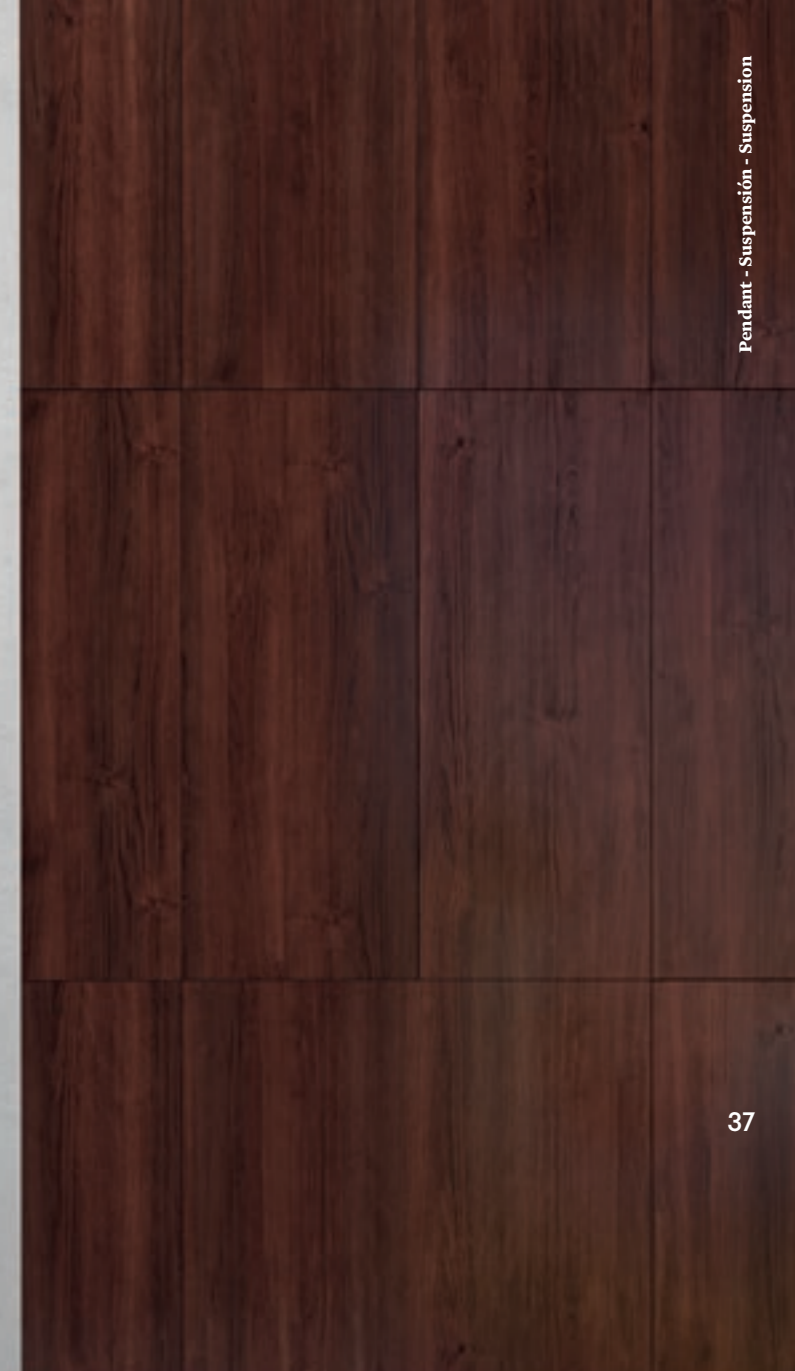
Candle





Benedito Design
Candle Triplex







Benedito Design
Candle Chandelier



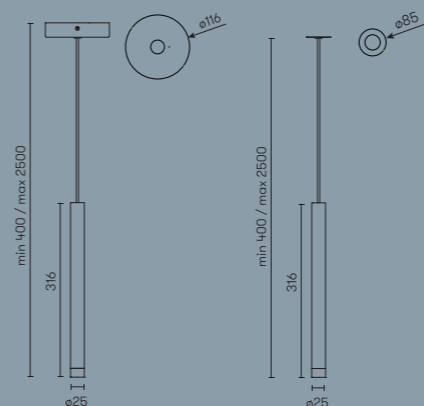



Candle


Poetic. This reinterpretation of a classic candelabra with an LED light source has given rise to this delicately radiant luminaire. Designed to create and accentuate spaces by emanating a poetic and refined light.

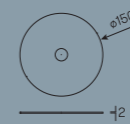
Poética. La reinterpretación de un candelabro clásico con fuente de luz led ha dado lugar a esta delicada luminaria que le confiere el valor de una joya. Pensada para crear y acentuar espacios gracias a la proyección de una luz poética y refinada.


Poétique. La réinterprétation d'un candélabre classique à source lumineuse LED a donné naissance à ce délicat luminaire qui prend des allures de bijou. Conçu pour créer et accentuer les espaces grâce à la projection d'une lumière poétique et raffinée.

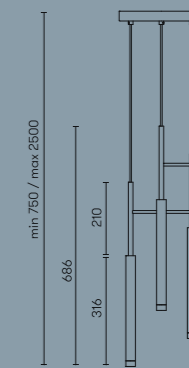



00-6017-27-27 
LED 3W | A++ A
174 lm 2700K

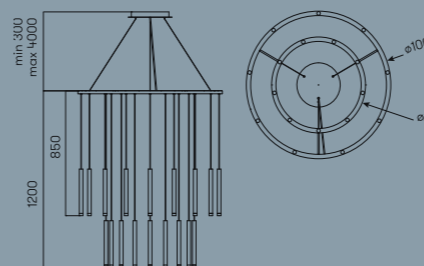
00-6018-27-27 
LED 3W | A++ A
174 lm 2700K





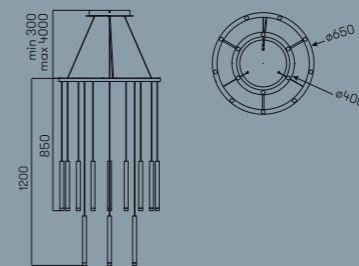
71-6022-27-27 
Optional accessory |
Accesorio opcional |
Accessoire en option





00-6021-27-27 (Mains dimming)* 
220-240V
LED 3x3W A++ A
522 lm 2700K




00-6066-27-27 (Dimmable 1-10V) 
00-6067-27-27 (Dimmable DALI) 
LED 15x3W | A++ A
3132 lm 2700K



00-6019-27-27 (Dimmable 1-10V) 
00-6020-27-27 (Dimmable DALI) 
LED 18x3W | A++ A
2610 lm 2700K



Finishing | Acabados | Finitions

 **27** Matt satin finished brass | Latón satinado mate | Laiton satiné mat

Materials | Materiales | Matériaux

ST Steel | Acero | Acier

PMMA Diffuser material PMMA | Material difusor
DIF PMMA | Matériau diffusant PMMA

* Mains dimmer compatibility at www.leds.c4.com [Products & Downloads]

* Compatibilidad con reguladores corte de fase en www.leds.c4.com [Productos & Descargas]

* Compatible avec des variateurs en coupure de phase que vous pouvez consulter www.leds.c4.com [Produits & Téléchargements]



Nahtrang Disseny

Tubs





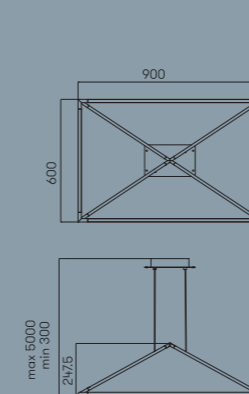


Tubs

Balance. With its unique design, the geometry of its pyramid-shaped lines trap the light inside, delicately highlighting and creating order wherever it is used. Its soft but powerful light makes it the perfect versatile accompaniment for large spaces.

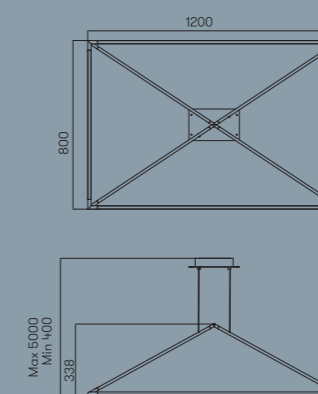
Equilibrio. De diseño único, su juego geométrico de líneas piramidales atrapa la luz en su interior marcando y ordenando con delicadeza los espacios donde se instala. Su tenue pero potente luz la presenta como una pieza versátil ideal para grandes espacios.

Équilibre. Avec un design unique, son jeu géométrique de lignes pyramidales capte la lumière à l'intérieur pour marquer et ajuster délicatement les espaces où elle est installée. Sa tenue, mais puissante lumière la présente comme une pièce polyvalente idéale pour les grands espaces.



00-5999-05-M1 ■
00-6001-05-M1 (Dimmable DALI) ■

LED 36W A++ A
3000K | 3900 lm



00-6000-05-M1 ■
00-6002-05-M1 (Dimmable DALI) ■

LED 48W A++ A
3000K | 5200 lm



Finishing | Acabados | Finitions

05 Black | Negro | Noir

Materials | Materiales | Matériaux

AL Aluminium | Aluminio | Aluminium

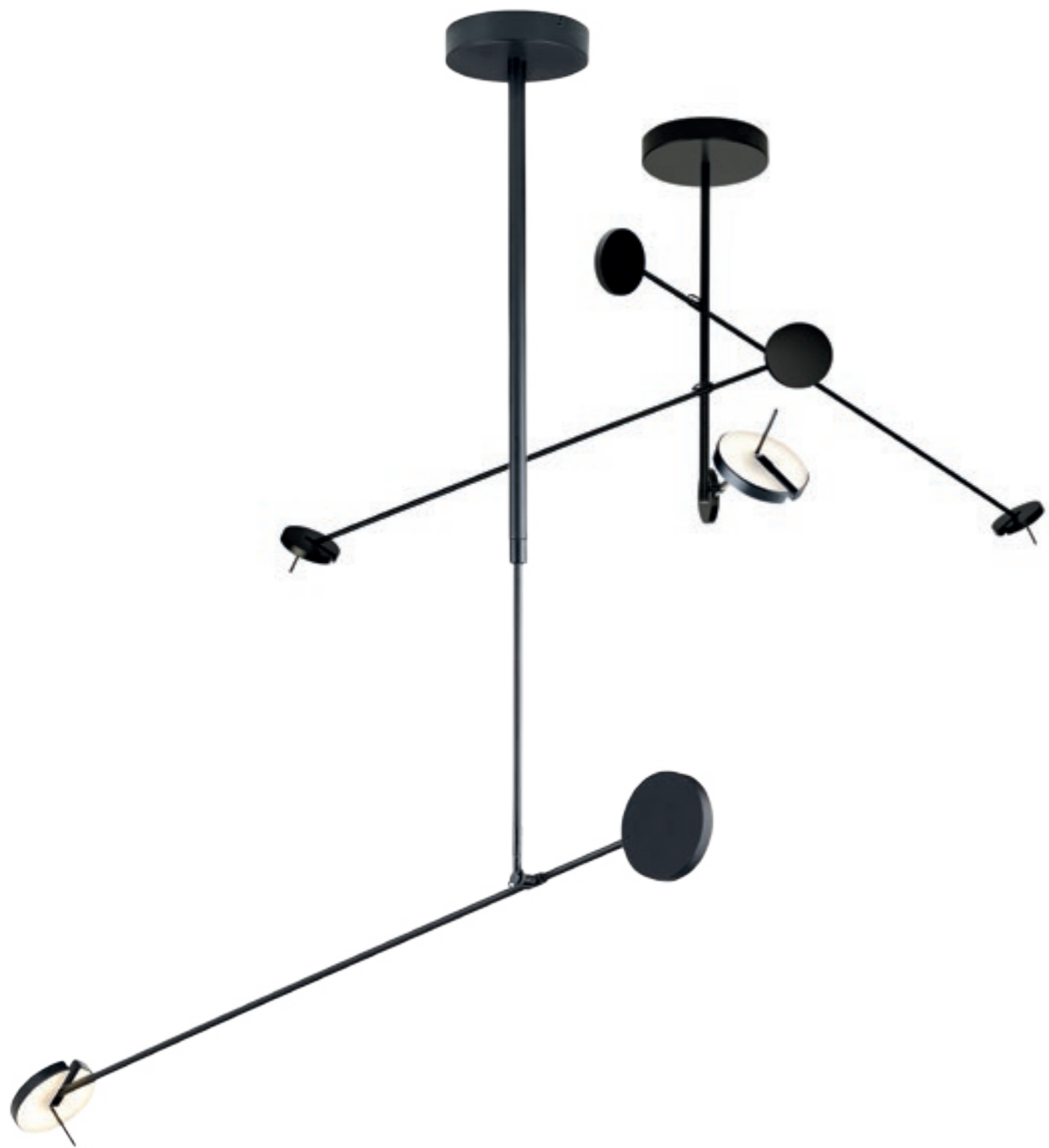
PMMA Diffuser material PMMA | Material difusor PMMA | Matériau diffusant PMMA



Francesc Vilaró

Invisible





Francesc Vilaró
Invisible





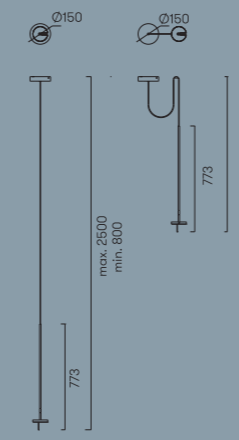


Invisible

Authenticity. The simplicity of this collection makes it unique and gives it authenticity and an individual identity. The different positions for its arms and heads generate multiple compositions that convey a sense of almost complete weightlessness reminiscent of a mobile.

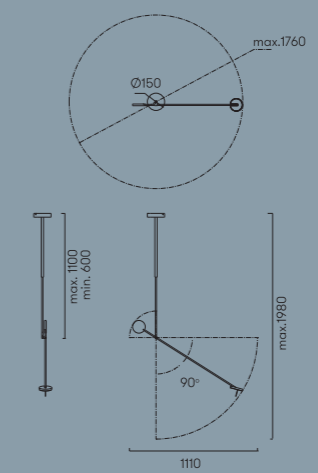
Autenticidad. La simplicidad de esta colección la hace única, auténtica y con identidad propia. Las diferentes posiciones de sus brazos y cabezales generan múltiples composiciones que transmiten una percepción casi de ingravidez que nos recuerda a un móvil.

Authenticité. La simplicité de cette collection la rend unique, authentique et avec une identité propre. Les différentes options de positions de ses bras et de ses têtes permettent de créer de multiples compositions qui donnent une perception d'apesanteur rappelant un mobile.



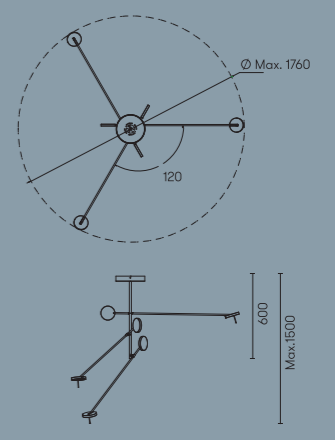
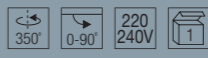
00-5693-05-05 (Mains dimming)* ■

LED 9W A++ A
765 lm 3000K



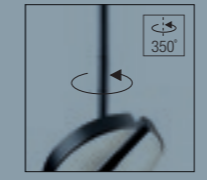
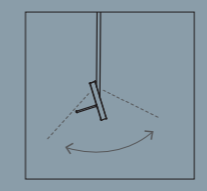
00-5694-05-05 (Mains dimming)* ■

LED 9W A++ A
765 lm 3000K



00-5695-05-05 (Standard) ■
00-5696-05-05 (Mains dimming)* ■

LED 27W A++ A
2295 lm 3000K



Finishing | Acabados | Finitions

05 Black | Negro | Noir

Materials | Materiales | Matériaux

ST Steel | Acero | Acier

PMMA Diffuser material PMMA | Material difusor PMMA | Matériau diffusant PMMA

* Mains dimmer compatibility at www.leds.c4.com (Products & Downloads)

* Compatibilidad con reguladores corte de fase en www.leds.c4.com (Productos & Descargas)

* Compatible avec des variateurs en coupure de phase que vous pouvez consulter www.leds.c4.com (Produits & Téléchargements)

Collection

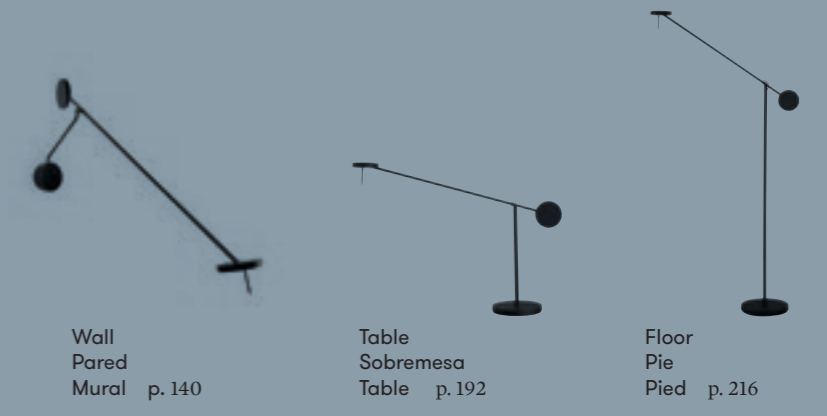
Illuminates your spaces alongside the other pieces that comprise this collection.

Colección

Ilumina tus espacios con el resto de piezas que componen esta colección.

Collection

Éclairer vos espaces avec le reste des pièces de cette collection.



Wall
Pared
Mural p. 140

Table
Sobremesa
Table p. 192

Floor
Pie
Pied p. 216



Josep Patsí

Circ



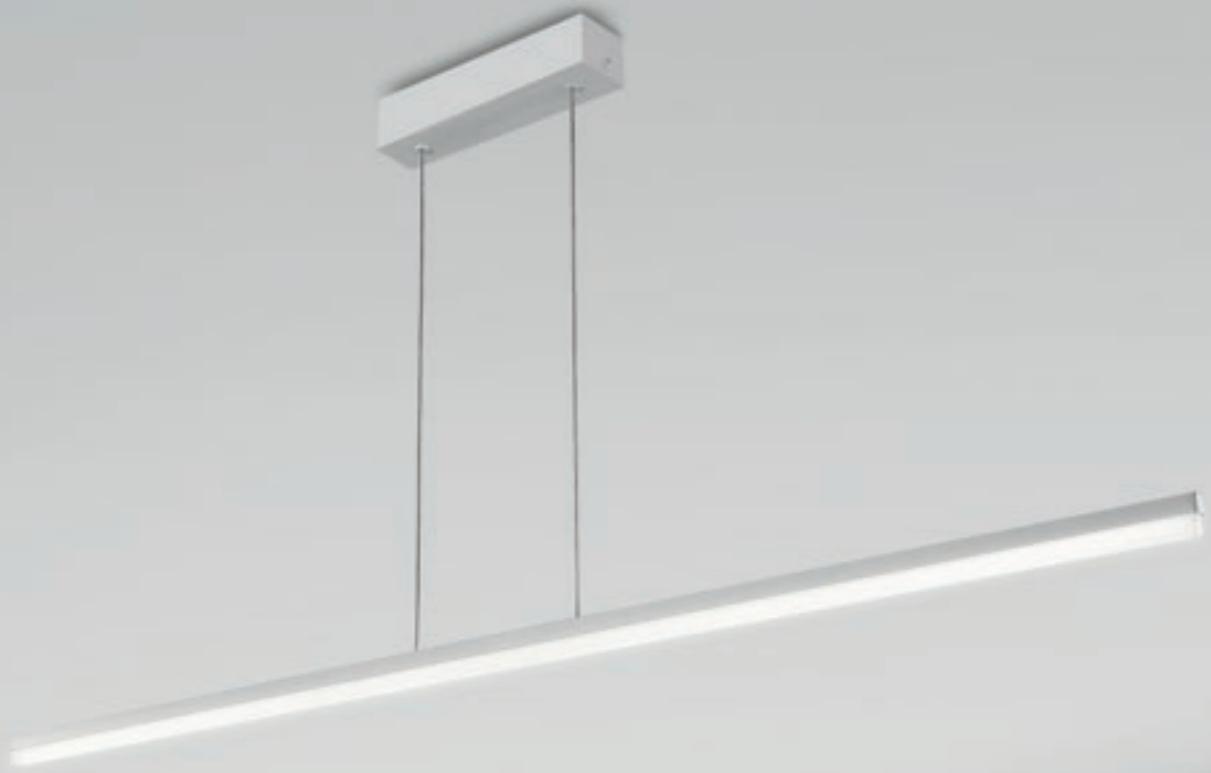


Josep Patsí
Circ









Josep Patsí
Circ

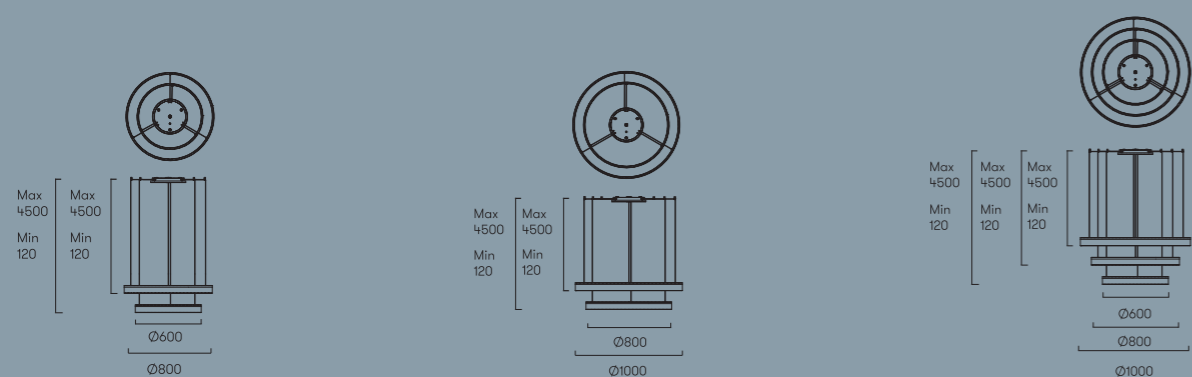


Circ

Lightness. The design of this pendant lamp offers diffuse lighting and provides great versatility in any space. It can be installed in a circular or linear format in a combination of different shapes and sizes.

Ligereza. El diseño de esta luminaria de suspensión ofrece una iluminación muy difusa y permite una gran versatilidad en los espacios. Puede instalarse de manera circular o lineal y realizar combinaciones de formas y tamaños diferentes.

Légèreté. Le design de ce luminaire en suspension offre un éclairage très diffus et permet une grande polyvalence dans l'espace. On peut l'installer de manière circulaire ou linéaire et réaliser des combinaisons de formes et de dimensions différentes.



00-3647-BW-M3 (Standard)

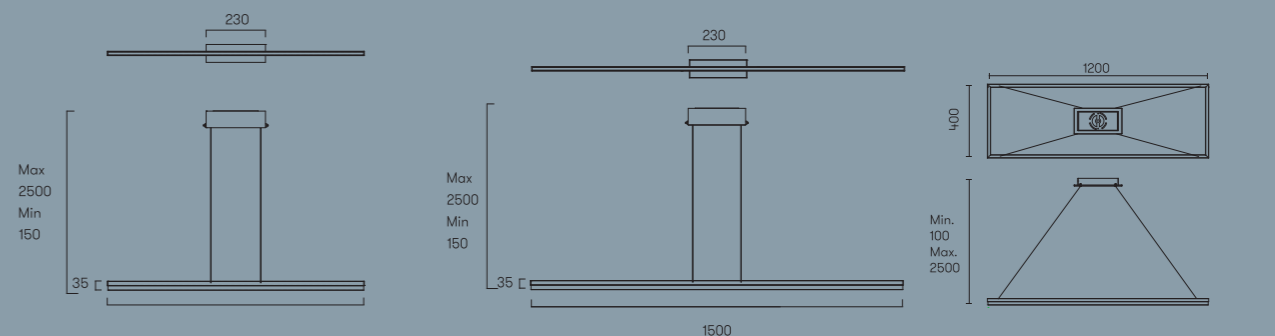
LED 53W | A++ A
5088 lm 3000K

00-3648-BW-M3 (Standard)

LED 67W | A++ A
6432 lm 3000K

00-3649-BW-M3 (Standard)

LED 89W | A++ A
8544 lm 3000K



00-2934-BW-M3V1 (Standard)
00-3643-BW-M3V1 (Dimmable 1-10V)

LED 18W | A++ A

1728 lm 3000K



00-2935-BW-M3V1 (Standard)
00-3644-BW-M3V1 (Dimmable 1-10V)

LED 27W | A++ A

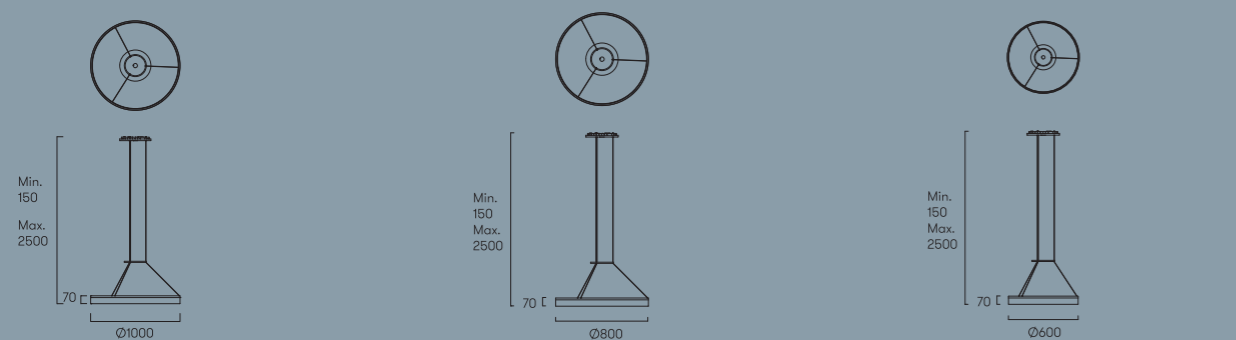
2592 lm 3000K



00-4876-BW-M3 (Standard)
00-4872-BW-M3 (Mains dimming)*

LED 34W | A++ A

3264 lm 3000K



00-3642-BW-M3 (Standard)
00-3646-BW-M3 (Dimmable 1-10V)

LED 36W | A++ A
3456 lm 3000K

00-0002-BW-M3 (Standard)
00-0642-BW-M3 (Dimmable 1-10V)

LED 31W | A++ A
2976 lm 3000K

00-0001-BW-M3 (Standard)
00-0641-BW-M3 (Dimmable 1-10V)

LED 22W | A++ A
2112 lm 3000K



Finishing | Acabados | Finitions

BW Matt white | Blanco mate | Blanc mate

Materials | Materiales | Matériaux

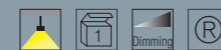
AL Aluminium | Aluminio | Aluminium

PMMA Diffuser material PMMA | Material difusor PMMA | Matériau diffusant PMMA



71-2241-00-00

Controller with remote control for **Standard Version** | Controlador con mando a distancia para **Versiones Standard** | Contrôleur avec télécommande pour **Versions Standard**



Finishing | Acabados | Finitions

BW Matt white | Blanco mate | Blanc mate

Materials | Materiales | Matériaux

AL Aluminium | Aluminio | Aluminium

PMMA Diffuser material PMMA | Material difusor PMMA | Matériau diffusant PMMA



71-2241-00-00

Controller with remote control for **Standard Version** | Controlador con mando a distancia para **Versiones Standard** | Contrôleur avec télécommande pour **Versions Standard**



* Mains dimmer compatibility at www.leds.c4.com [Products & Downloads]

* Compatibilidad con reguladores corte de fase en www.leds.c4.com [Productos & Descargas]

* Compatible avec des variateurs en coupure de phase que vous pouvez consulter www.leds.c4.com [Produits & Téléchargements]

Collection

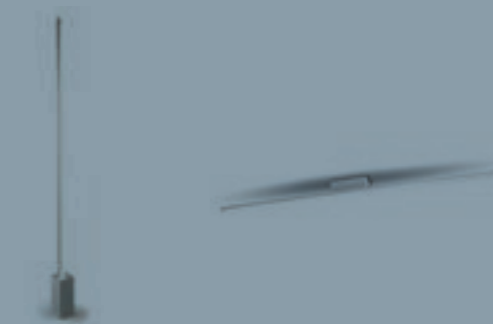
Illuminates your spaces alongside the other pieces that comprise this collection.

Colección

Ilumina tus espacios con el resto de piezas que componen esta colección.

Collection

Éclairer vos espaces avec le reste des pièces de cette collection.



Floor
Pie
Pied

p. 242

Ceiling
Techo
Plafond

p. 260



WIS Design

Umbrella



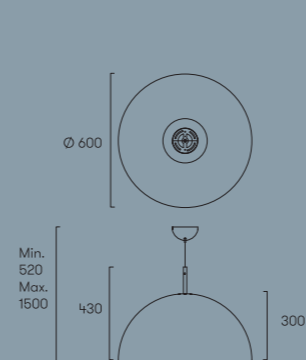


Umbrella

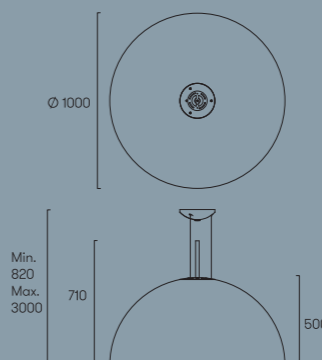
Radiant. This luminaire draws its design inspiration from an umbrella on a sunny day, with the sun's rays shining through the fabric creating soft reflections of light. It is available in two sizes and two colour combinations: black and gold or white and silver.

Radiante. Esta luminaria debe su diseño a un paraguas en un día soleado en el que los rayos de sol atraviesan su tela creando suaves reflejos de luz. Está disponible en dos tamaños y en dos combinaciones de colores: negro/dorado o blanco/plata.

Rayonnant. Ce luminaire évoque un parasol qui laisse passer les rayons du soleil à travers son tissu, de manière à créer de doux reflets de lumière. Disponible en deux dimensions et deux combinaisons de couleur : noir/doré ou blanc/argent.



00-2727-AP-05
 00-2727-AQ-78
 3 x E-14 Max. 11W |
 Max. L=145mm Ø=45mm
 A++ C
 Fluorescent - LED



00-2726-AP-05
 00-2726-AQ-78
 3 x E-27 Max. 23W |
 Max. L=150mm Ø=60mm
 A++ C
 Fluorescent - LED



Finishing | Acabados | Finitions

- 05** Black | Negro | Noir + **AP** Golden pleated interior shade | Pantalla interior plisada dorada | Intérieur d'abat-jour plissé doré
- 78** White lacquered | Lacado blanco | Laqué en blanc + **AQ** Metallic grey. Silver pleated interior shade | Gris metalizado. Pantalla interior plisada plata | Gris métallisé. Intérieur d'abat-jour plissé argenté

Materials | Materiales | Matériaux

- GLASS MAT** Diffuser material matt glass | Material difusor vidrio mate | Matériau diffusant Verre
- PMMA** PMMA | PMMA | PMMA
- TEXTIL** Fabric | Tela | Tissu



Francesc Vilaró

Alive





Francesc Vilaró
Alive





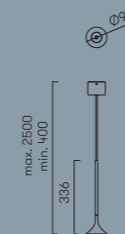
Francesc Vilaró
Alive

Alive

Clarity. Its timeless design is based on the bare minimum required for illumination; the light source. Its multiple configurations allow various lighting needs to be personalised and resolved. The high-quality frosted glass lampshade offers a silky, diffuse and warm light.

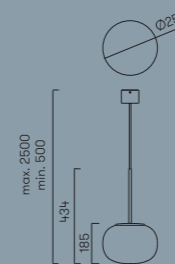
Claridad. Su diseño atemporal se basa en el elemento mínimo necesario para iluminar, la fuente de luz. Sus múltiples configuraciones permiten personalizar y dar soluciones a diferentes necesidades lumínicas. El cristal matizado de alta calidad de la pantalla ofrece una luz sedosa, difusa y cálida.

Clarté. Son design intemporel est basé sur l'élément minimal nécessaire pour éclairer : la source de lumière. Ses multiples configurations permettent de personnaliser et de fournir des solutions aux différents besoins d'éclairage. L'écran en verre trempé de grande qualité offre une lumière soyeuse, chaude et diffuse.



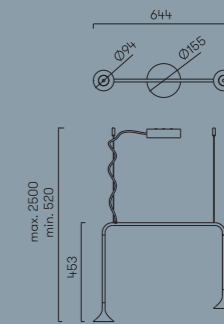
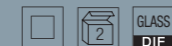
00-5284-21-21
00-5284-BW-BW

LED CREE 7W | A++ A
612 lm 2700K



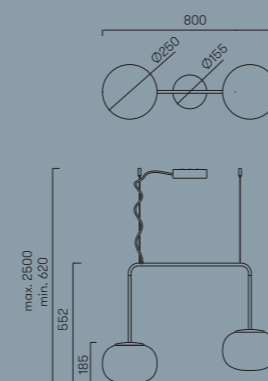
00-5285-21-F1
00-5285-BW-F1

LED CREE 7W | A++ A
612 lm 2700K



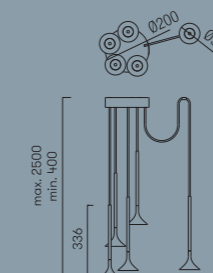
00-5286-21-21
00-5286-BW-BW

2 x LED CREE 14W | A++ A
1224 lm 2700K



00-5287-21-F1
00-5287-BW-F1

2 x LED CREE 14W | A++ A
1224 lm 2700K



00-5291-21-21
00-5291-BW-BW

5 x LED CREE 35W | A++ A
3060 lm 2700K



Finishing | Acabados | Finitions

BW Matt white | Blanco mate | Blanc mate
21 Chrome | Cromo | Chrome

Materials | Materiales | Matériaux

AL Aluminium | Aluminio | Aluminium

GLASS Diffuser material glass | Material difusor
DIF Cristal | Matériau diffusant Verre



Josep Patsí

Hello





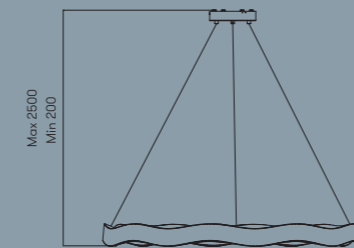
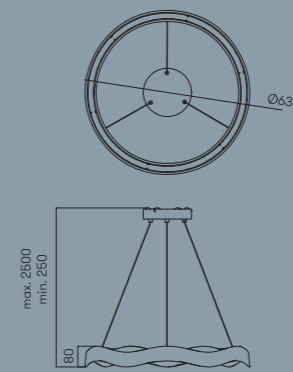
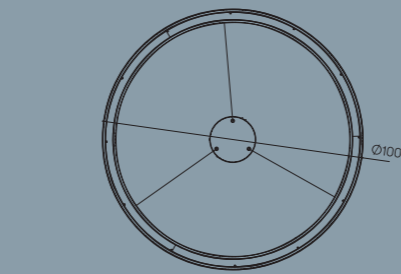
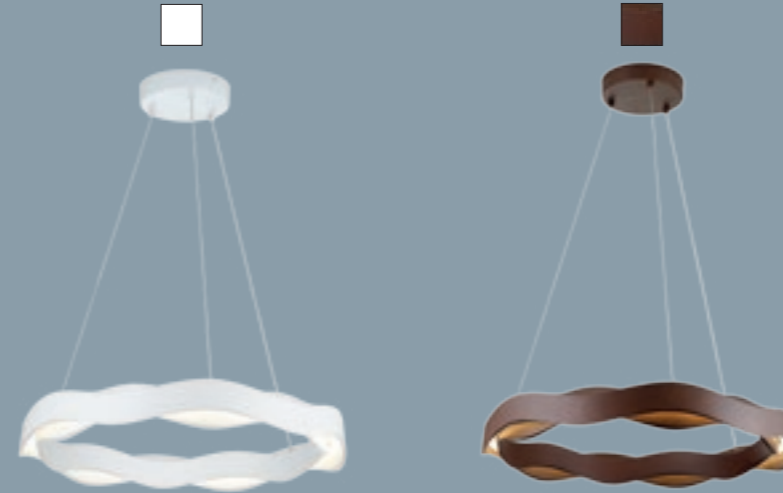
Hello

Harmony. The sea and waves are the main source of inspiration. Its shapes and contrasts generate an intimate atmosphere through warm and comfortable light. Lending its personality to wherever it is installed and its visual comfort harmonises spaces with different styles.

Armonía. El mar y sus olas son su principal inspiración. Sus formas y contrastes generan un clima íntimo mediante una luz cálida y confortable. Otorga personalidad donde se ubica y su confort visual armoniza espacios de diferentes estilos.

Harmonie. La mer et ses vagues sont sa principale source d'inspiration. Ses formes et ses contrastes créent une atmosphère intime avec une lumière chaude et confortable. Elle apporte de la personnalité à l'endroit où elle se trouve et son confort visuel harmonise les espaces de styles différents.

Finishing | Acabados | Finitions



00-5958-BW-M1 (Mains dimming)* ■ 2700K

LED 33,5W | A++ A
3450 lm

00-5275-BW-M1 (Mains dimming)* ■ 3000K
00-5498-BW-M1 (Mains dimming)* ■ 3000K
00-5275-CT-M1 (Mains dimming)* ■ 2700K

LED 24,3W | A++ A
2300 lm



Finishing | Acabados | Finitions

- BW Matt white | Blanco mate | Blanc mate
- CT Wood brown | Marrón madera | Bois marron

Materials | Materiales | Matériaux

- PMMA Diffuser material PMMA | Material difusor PMMA | Matériau diffusant PMMA
- PUR Polyurethane | Poliuretano | Polyuréthane

* Mains dimmer compatibility at www.leds.c4.com (Products & Downloads)

* Compatibilidad con reguladores corte de fase en www.leds.c4.com (Productos & Descargas)

* Compatible avec des variateurs en coupure de phase que vous pouvez consulter www.leds.c4.com (Produits & Téléchargements)



Nahtrang Disseny

Talk





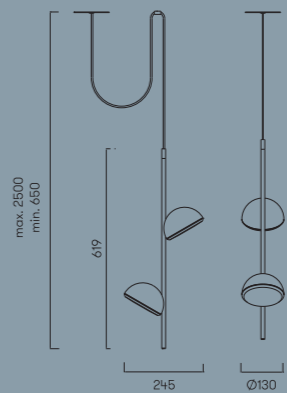
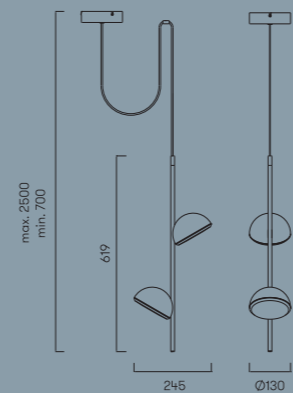
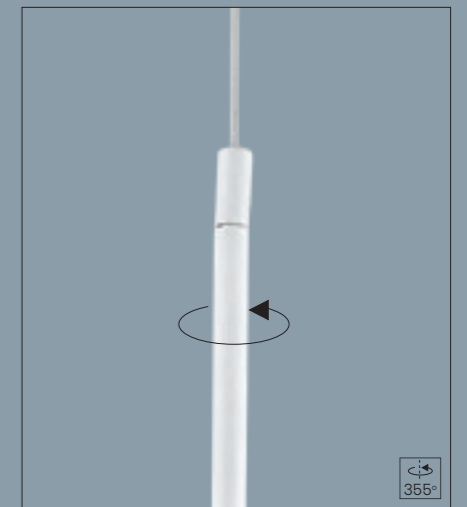
Talk

Vibrancy. A sky full of bright points of light appears when the daylight fades. Its vibrancy and geometry establish a connection between these points by creating its own language. Its compositions range from the basic minimum to the infinite. Hanging vines that can be used to fill all types of spaces.

Dinamismo. Un cielo de puntos brillantes aparecen cuando la luz del día cae. Su dinamismo y geometría establece una conexión entre ellos generando un lenguaje propio. Sus composiciones van desde el elemento mínimo hasta el infinito. Lianas colgantes que llenan todos los espacios.

Dynamisme. Un ciel de points brillants apparaît lorsque la lumière du jour tombe. Son dynamisme et sa géométrie établissent un lien entre eux créant un langage propre. Ses compositions vont de l'élément le plus minime à l'infini. Des lianes suspendues qui remplissent tous les espaces.

Finishing | Acabados | Finitions



Finishing | Acabados | Finitions

- BW** Matt white | Blanco mate | Blanc mate
- Z5** Anthracite Grey | Gris Antracita | Gris Anthracite

Materials | Materiales | Matériaux

- AL Aluminium | Aluminio | Aluminium
- GLASS Diffuser material glass | Material difusor vidrio | Matériau diffusant Verre
- DIF

00-5457-BW-F9
00-5457-Z5-F9

2 x LED CREE 13W A++ A
2700K 1390 lm

00-5458-BW-F9
00-5458-Z5-F9

2 x LED CREE 13W A++ A
2700K 1390 lm Ø60mm

Collection

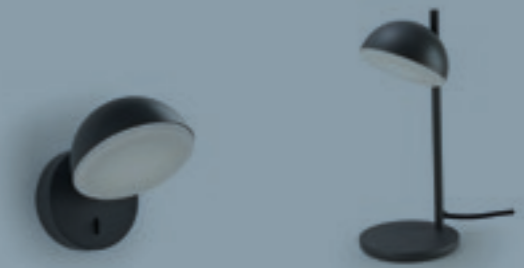
Illuminates your spaces alongside the other pieces that comprise this collection.

Colección

Ilumina tus espacios con el resto de piezas que componen esta colección.

Collection

Éclairiez vos espaces avec le reste des pièces de cette collection.



Wall
Pared
Mural p. 172

Table
Sobremesa
Table p. 210



Josep Patsí

Balloons



Balloons

Aesthetic. With its spherical shape and composition, this luminaire combines different top-quality materials including blown opal glass, steel and fabric. These give its interior and exterior a discreet and elegant aesthetic.

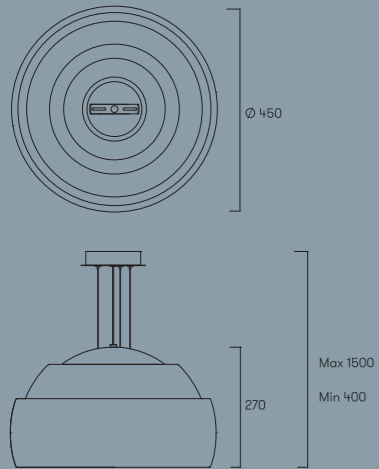
Estética. De forma y composición esférica, esta luminaria combina diferentes materiales nobles como el vidrio ópalo soplado, el acero y el tejido. Todo ello la dota de una estética interior y exterior muy cuidada y sin protagonismos.



Esthétique. De forme et composition sphériques, ce luminaire décline différents matériaux nobles comme le verre opalin soufflé, l'acier et le tissu. Le tout lui confère une esthétique intérieure et extérieure très soignée en toute discrétion.

Finishing | Acabados | Finitions



88





00-4348-21-F9 
00-4348-BW-F9 

1 x E-27 Max. 150W | Max. L=195mm Ø=60mm A++ C
Fluorescent - LED



Finishing | Acabados | Finitions

 21 Chrome | Cromo | Chrome


 BW Matt white | Blanco mate | Blanc mate


+

 White | Blanco | Blanc
 Orange | Naranja | Orange
 Green | Verde | Vert

00-4348-BW-F9
3 interchangeable indoor screens included |
3 pantallas interiores intercambiables incluidas |
3 abat-jour intérieurs et interchangeables inclus

Materials | Materiales | Matériaux

 Diffuser material triplex Opal glass | Material difusor cristal opal triplex | Matériau diffusant verre opal triplex

 Steel | Acero | Acier

 Fabric | Tela | Tissu

89



Gemma Bernal

Bamboo

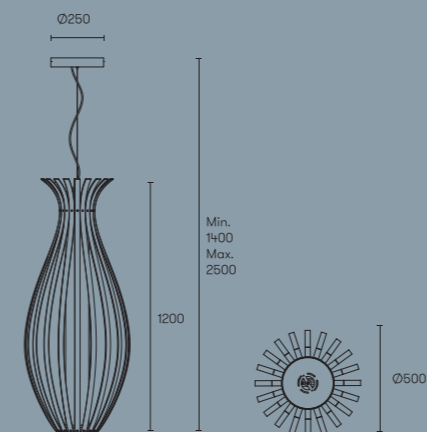


Bamboo

Honesty. Made from fine, natural and eco-friendly materials, such as bamboo, they integrate perfectly into both warm and architectural spaces. Given their size, they can be installed in large spaces to create low-cost, efficient lighting.

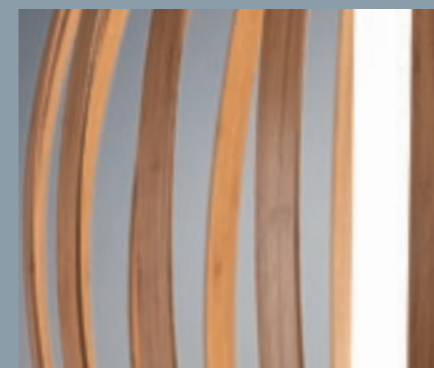
Honestidad. Elaboradas con un producto noble, natural y ecológico como el bambú, se integran perfectamente en todos los espacios, tanto en cálidos como en arquitectónicos. Por sus dimensiones pueden instalarse en grandes espacios y generan una luz de bajo coste y suficiente.

Honnêteté. Issues d'un produit noble, naturel et biologique tel que le bambou, elles s'intègrent parfaitement dans tous les espaces aussi bien chauds et qu'architecturaux. Compte tenu des dimensions, elles peuvent être installées dans de grands espaces et génèrent une lumière suffisante à un faible coût.



00-4034-CT-93 (Dimmable 1-10V) ■

LED 22W A++ A
3000K 1870 lm



Bamboo | Bambú | Bambou



Finishing | Acabados | Finitions

CT Wood brown | Marrón madera | Bois marron

Materials | Materiales | Matériaux

ST Steel | Acero | Acier

WOOD Wood | Marrón | Bois

PMMA Diffuser material PMMA | Material difusor PMMA | Matériau diffusant PMMA

Collection

Illuminates your spaces alongside the other pieces that comprise this collection.

Colección

Ilumina tus espacios con el resto de piezas que componen esta colección.

Collection

Éclairiez vos espaces avec le reste des pièces de cette collection.



Floor
Pie
Pied p. 237



Josep Patsí

Clear

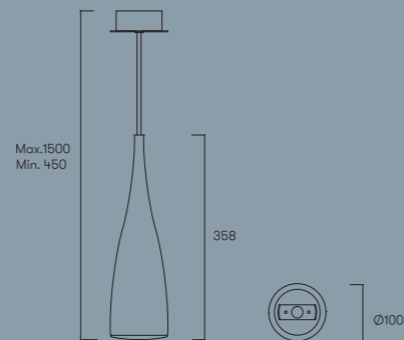
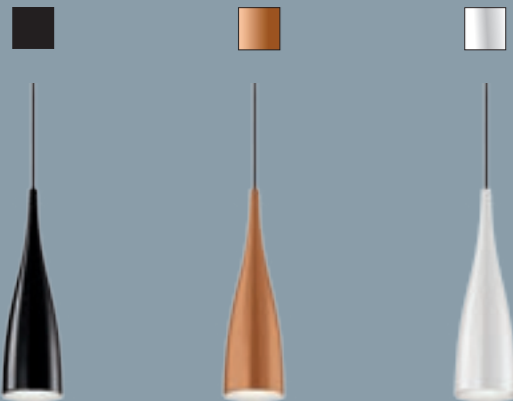
Clear

Feminine. This light, fresh and timeless piece is characterised by its elegant feminine form. The purity of its lines, its lacquered finish and anti-glare diffuser makes this the ideal option for bar counters, shops or reception areas.

Femenina. Esta pieza ligera, fresca y atemporal se caracteriza por su forma femenina y elegante. La pureza de sus líneas, sus acabados lacados y el difusor anti alumbramiento la propone como una luminaria perfecta para barras de bar, tiendas o recepciones.

Féminin. Léger, frais et intemporel, ce modèle se distingue par sa forme féminine et élégante. Lignes pures, finitions laquées et diffuseur anti-éblouissement sont autant d'atouts qui en font le luminaire idéal pour les comptoirs de bar, de magasins ou de halls d'accueil.

Finishing | Acabados | Finitions



00-2872-05-M2
00-2872-06-M2
00-2872-78-M2

1 x E-27 | Par-20 Max. 50W | Max. L=170mm
Ø=64mm A++ C
Fluorescent - LED
Recommended E-27 PAR-20 50W

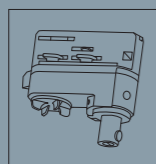


Finishing | Acabados | Finitions

- 05 Black | Negro | Noir
- 06 Copper | Cobre | Cuivre
- 78 White lacquered | Lacado blanco | Laqué en blanc

Materials | Materiales | Matériaux

- ST Steel | Acero | Acier
- PC Diffuser material polycarbonate | Material difusor Policarbonato | Matériau diffusant Polycarbonate



71-2232-14-14
Track Connector |
Conector de Carril |
Connecteur de Rail

Top diffuser | Difusor Superior | Diffuseur Supérieur



Francesc Vilaró

Emy

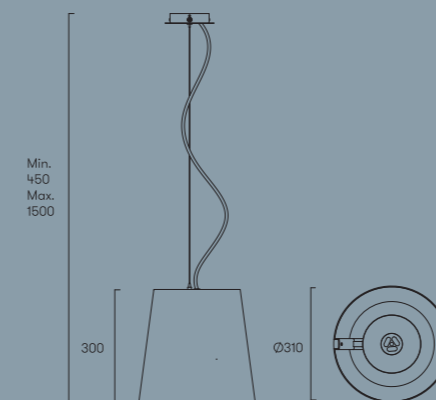


Emy

Elegance. With classical and elegant forms, its design is based on the use of materials and the effects generated by the light on them. The carefully designed shape of its polycarbonate lampshade creates the almost holographic effect of a second lampshade inside.

Elegancia. De formas clásicas y elegantes, su diseño se basa en el uso de los materiales y los efectos que genera la luz sobre ellos. Su estudiada trama de la pantalla de policarbonato genera un efecto de casi holograma de la segunda pantalla interior.

Élégance. Aux formes classiques et élégantes, son design est basé sur l'utilisation de matériaux et les effets générés par la lumière sur ceux-ci. La trame étudiée de l'écran en polycarbonate génère un effet d'hologramme du second écran interne.



00-4409-21-12

1 x E-27 Max. 30W | Max. L=180mm Ø=60mm A++ C
Fluorescent - LED



Finishing | Acabados | Finitions

SHADE 12 Smoked acrylic shade | Pantalla acrílico fumé | Abat-jour acrylique fumé

21 Chrome | Cromo | Chrome

Materials | Materiales | Matériaux

AL Aluminium | Aluminio | Aluminium

PMMA Diffuser material PMMA | Material difusor PMMA | Matériau diffusant PMMA

PC Shade material Polycarbonate | Material pantalla Polycarbonato | Matériels Abat-jour Polycarbonate

Collection

Illuminates your spaces alongside the other pieces that comprise this collection.

Colección

Ilumina tus espacios con el resto de piezas que componen esta colección.

Collection

Éclairiez vos espaces avec le reste des pièces de cette collection.



Wall
Pared
Mural p. 175



Table
Sobremesa
Table p. 212



Floor
Pie
Pied p. 234



Josep Patsí

Net



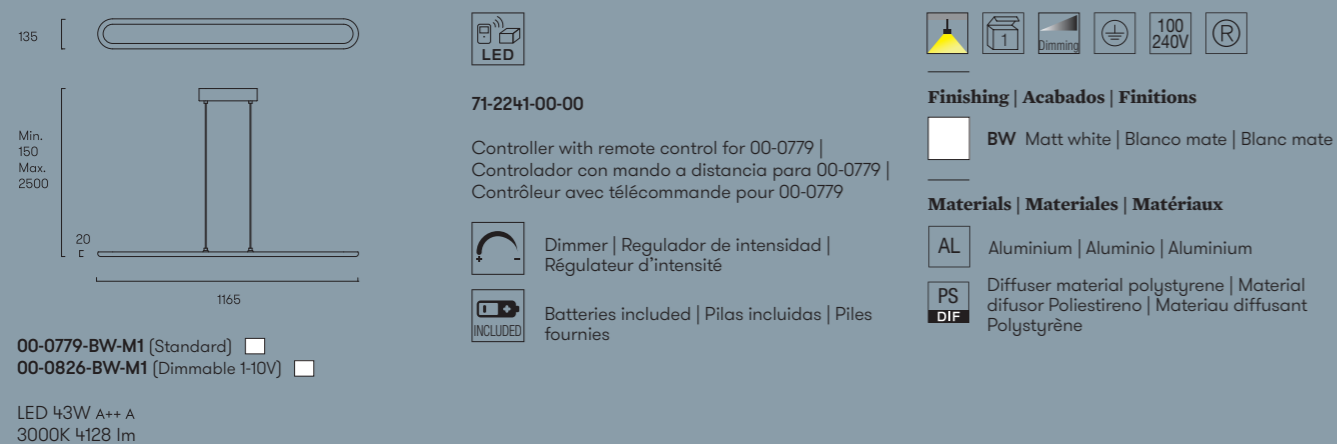
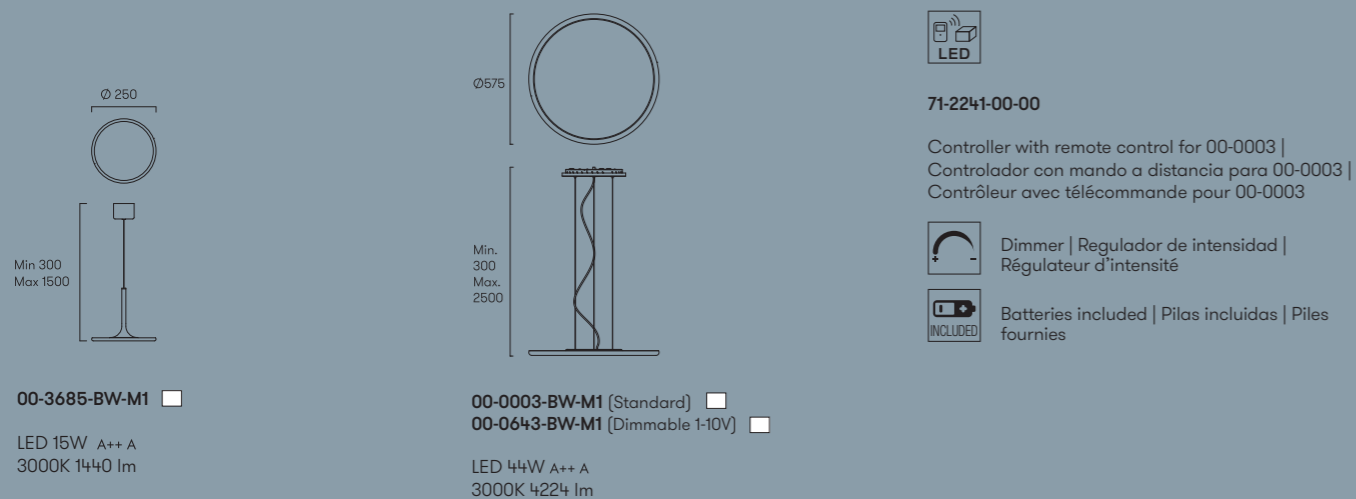


Net

Purity. Its flat, slimline design with very clean forms allows it to be used in various formats and applications within any space. Discreet, but at the same time versatile, this piece is available in a circular or oval shape.

Pureza. Su diseño plano, delgado y de formas muy limpias le permite varios formatos y aplicaciones en el espacio. Discreta y versátil al mismo tiempo, esta pieza está disponible en forma de circunferencia u óvalo.

Pureté. Son design plat, fin et aux formes très épurées lui permet d'adopter différents formats et applications dans l'espace. À la fois discret et polyvalent, ce modèle est disponible en forme de circonférence ou d'ovale.



Collection

Illuminates your spaces alongside the other pieces that comprise this collection.

Colección

Ilumina tus espacios con el resto de piezas que componen esta colección.

Collection

Éclairer vos espaces avec le reste des pièces de cette collection.



Ceiling
Techo
Plafond p. 262



Gemma Bernal

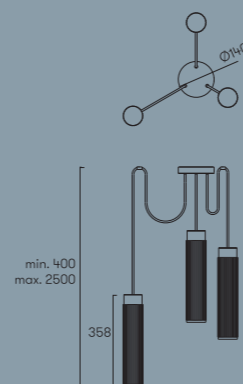
Rigatto

Rigatto

Timelessness. With a more architectural finish, this luminaire offers various informal and varied points of light. Its warm design and timeless look mean it can be used individually or in groups at different heights to create asymmetrical and disorganised compositions.

Atemporalidad. De acabado más arquitectónico, ofrece varios puntos de luz, cercanos y desiguales. Por su diseño cálido y de aspecto atemporal, pueden utilizarse individualmente o agrupadas en distintas alturas generando composiciones asimétricas y desordenadas.

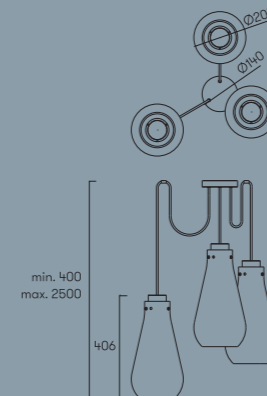
Intemporalité. Aux finitions plus architecturales, elle offre plusieurs points de lumière, proches et inégaux. Par son design chaleureux et son aspect intemporel, elle peut être utilisées individuellement ou regroupées à différentes hauteurs, créant des compositions asymétriques et fantaisistes laissant cours à l'imagination



00-5278-21-21 (Mains dimming)*
 00-5278-BW-BW (Mains dimming)*
 00-5494-BW-BW (Mains dimming)*

2700K
 2700K
 3000K

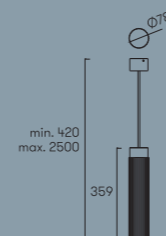
3 × LED CREE 21,6W A++ A
 2325 lm



00-5279-21-37 (Mains dimming)*
 00-5279-BW-37 (Mains dimming)*
 00-5495-BW-37 (Mains dimming)*

2700K
 2700K
 3000K

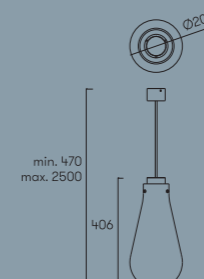
3 × LED CREE 21,6W A++ A
 2325 lm



00-5280-21-21 (Mains dimming)*
 00-5280-BW-BW (Mains dimming)*
 00-5496-BW-BW (Mains dimming)*

2700K
 2700K
 3000K

LED CREE 7,2W A++ A
 775 lm



00-5281-21-37 (Mains dimming)*
 00-5281-BW-37 (Mains dimming)*
 00-5497-BW-37 (Mains dimming)*

2700K
 2700K
 3000K

LED CREE 7,2W A++ A
 775 lm



Finishing | Acabados | Finitions

21 Chrome | Cromo | Chrome

BW Matt white | Blanco mate | Blanc mate

Materials | Materiales | Matériaux

AL Aluminium | Aluminio | Aluminium

PMMA Diffuser material PMMA | Material difusor PMMA | Matériau diffusant PMMA

*Mains dimmer compatibility at www.leds.c4.com (Products & Downloads)

*Compatibilidad con reguladores corte de fase en www.leds.c4.com (Productos & Descargas)

*Compatible avec des variateurs en coupure de phase que vous pouvez consulter www.leds.c4.com (Produits & Téléchargements)



Francesc Vilaró

Ringofire



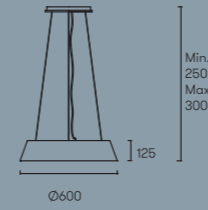


Ringofire

Comfort. A reinterpretation and update to the traditional pendant lamp with LED technology. Its timeless design is suited for use in both domestic and contract spaces. The full-empty concept incorporated in its volumes gives it visual lightness and optimum lighting comfort.

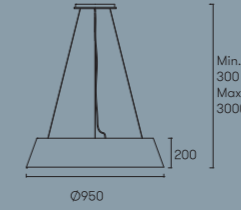
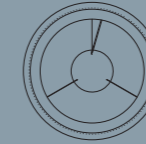
Confortabilidad. Reinterpretación y actualización de las tradicionales lámparas de suspensión con tecnología led. Su diseño atemporal encaja tanto en el uso doméstico como en espacios contract. El concepto lleno-vacío en los volúmenes la dota de ligereza visual y de óptimo confort lumínico.

Confort. Réinterprétation et actualisation des traditionnelles lampes à suspension avec la technologie LED. Son design intemporel correspond aussi bien à un usage domestique qu'à des espaces professionnels. Les volumes de concept vide-plein lui donnent une légèreté visuelle optimale et un confort d'éclairage.



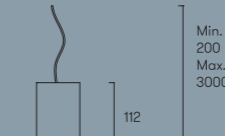
00-0053-05-BW

LED 26W
3000K 974 lm
A++ A



00-0054-05-BW

LED 41W
3000K 1536 lm
A++ A



71-0053-BW-BW

1 x GU10 Max. 15W
Max. L= 100mm Ø=111mm LED
A++ C

Recommended:
ACT-FLL-015 10W 24o
ACT-FLL-017 10W 35o
ACT-FLL-032 15W 24o
ACT-FLL-033 15W 35o



Finishing | Acabados | Finitions

- 05 Black | Negro | Noir
- BW Matt white | Blanco mate | Blanc mate

Materials | Materiales | Matériaux

- ST Steel | Acero | Acier
- PUR Polyurethane | Poliuretano | Polyuréthane



Josep Patsí

Angie

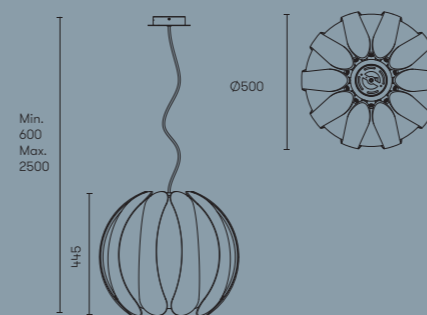
Angie

Magic. Called "Angel wings" in Eastern cultures, its spherical composition and the effect of the light between its vertical slats creates a magical ambience. The elegant but bold design gives this piece great presence and personality.

Magia. Llamada "Alas de ángel" por los orientales, su composición esférica y el efecto de la luz entre sus lamas verticales crea ambientes mágicos. Su diseño elegante pero atrevido al mismo tiempo, la presenta como una pieza con mucha presencia y personalidad.

Magique. Appelé «Aile d'ange» en Orient, la composition de ce modèle sphérique et l'effet de sa lumière entre les lames verticales crée des ambiances magiques. Sa ligne élégante et audacieuse en fait un article à forte présence et personnalité.

Finishing | Acabados | Finitions



00-3543-BW-BW
00-3543-F5-F5

1 x E-27 Max. 100W | Max.L=200mm. Ø=150mm A++ C
Fluorescent - LED



Finishing | Acabados | Finitions

F5 Painted gold | Oro pintado | Or peint
BW Matt white | Blanco mate | Blanc mate

Materials | Materiales | Matériaux

ABS ABS | ABS | ABS

ST Steel | Acero | Acier



Josep Patsí

Aura

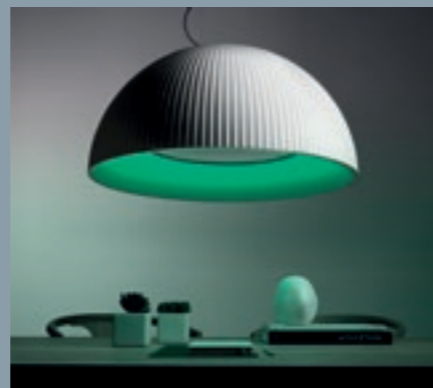


Aura

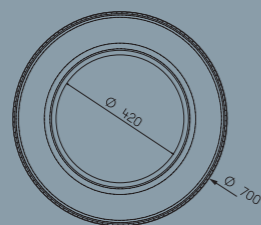
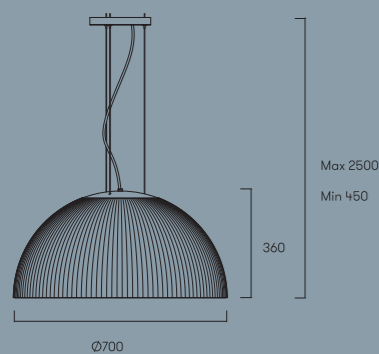
Multifunctionality. With its hemispherical composition and vertical ribbing, this piece provides a special light for any occasion. Its multifunctional light, effects and colour adapt to different ambiances and create multiple scenes.

Multifuncionalidad. De composición semiesférica con un estriado vertical, ofrece una iluminación especial para cada momento. Su iluminación multifunción, efectos y color, se adapta a diferentes atmósferas y crea múltiples escenas.

Multifonctionnalité. De composition semi-sphérique à stries verticales, ce luminaire assure un éclairage spécial pour chaque moment. Son éclairage multifonctionnel, ses effets et sa couleur permettent de l'adapter à différents décors et de créer de nombreuses mises en scène.



Included



Finishing | Acabados | Finitions

BW Matt white | Blanco mate | Blanc mate

Materials | Materiales | Matériaux

PMMA Diffuser material PMMA | Material difusor PMMA | Matériau diffusant PMMA

PUR Polyurethane | Poliuretano | Polyuréthane

Independent paired lighting system | Sistema de doble iluminación independiente | Système à double éclairage indépendant

00-1942-BW-M3

LED 40W
3000K 3840 lm
LED 10W
A++ A
RGB



WIS Design

Blomma



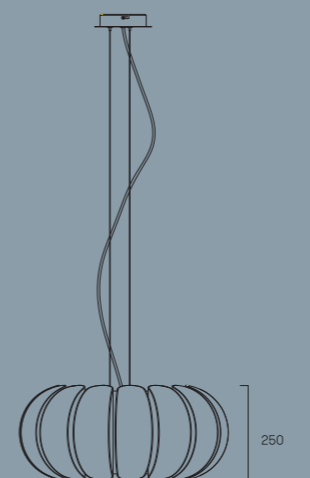
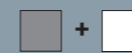
Blomma

Organic. This luminaire, with organic forms and lines, is inspired by a flower, the petals of which appear to float freely around the light. It is available in black, grey and red.

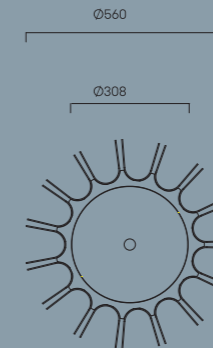
Orgánica. De formas y líneas orgánicas, esta luminaria se inspira en una flor en la que sus pétalos parecen flotar libremente alrededor de la luz. Está disponible en color negro, gris y rojo.

Organique. De formes et lignes organiques, ce luminaire s'inspire d'une fleur dont les pétales semblent flotter librement autour de la lumière. Il est disponible en coloris noir, gris et rouge.

Finishing | Acabados | Finitions



Min.
350
Max.
1500



250



Finishing | Acabados | Finitions



03 Grey | Gris | Gris + **BW** Matt white | Blanco mate | Blanc mate

05 Black | Negro | Noir + **BW** Matt white | Blanco mate | Blanc mate

Materials | Materiales | Matériaux

ABS ABS | ABS | ABS

PMMA Diffuser material PMMA | Material difusor PMMA
DIF PMMA | Matériau diffusant PMMA

00-4391-BW-03 
00-4391-BW-05 

3 x E-27 Max. 30W | Max. L=140mm Ø=60mm A++ C
Fluorescent - LED



Benedito Design

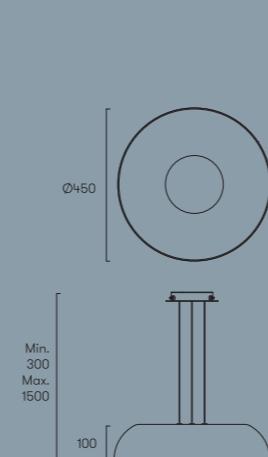
Tandem

Tandem

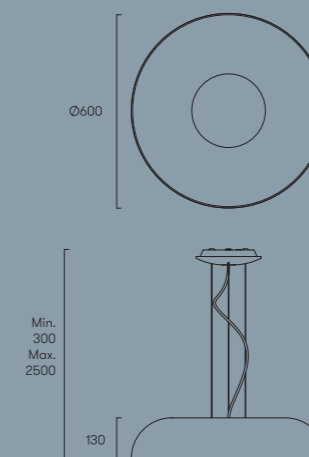
Rational. Evocative of timeless architecture, this pendant lamp includes a high-efficiency diffuser to produce warm and comfortable light. It is a reinterpretation of a classic design using LED technology.

Racional. Evocadora de arquetipos atemporales, esta lámpara colgante aporta un difusor de alta eficiencia para obtener una iluminación cálida y confortable. Se trata de una reinterpretación de un clásico con tecnología leds.

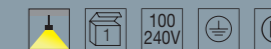
Rationnel. De ligne intemporelle, ce luminaire en suspension est muni d'un diffuseur à haute efficacité qui permet d'obtenir un éclairage chaleureux et confortable. Il s'agit d'une réinterprétation d'un classique avec la technologie LED.



00-6008-BW-M1

LED 15W
2700K 1600 lm

00-6009-BW-M1

LED 27W
2700k 2850 lm

Finishing | Acabados | Finitions

BW Matt white | Blanco mate | Blanc mate

Materials | Materiales | Matériaux

ST Steel | Acero | Acier

PMMA Diffuser material PMMA | Material difusor PMMA | Matériau diffusant PMMA

DIF

Collection

Illuminates your spaces alongside the other pieces that comprise this collection.

Colección

Ilumina tus espacios con el resto de piezas que componen esta colección.

Collection

Éclairer vos espaces avec le reste des pièces de cette collection.



Ceiling
Techo
Plafond p. 266



Josep Patsí

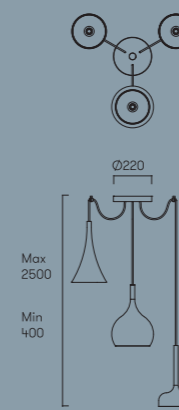
Sixties

Sixties

Vintage. With a look that's somewhere between Nordic and vintage, these three pendant lights are suitable for all kinds of spaces and can be placed either separately or together. The Sixties style, maintaining elegance and formal simplicity, and their direct, focused light makes them ideal for hotels, restaurants and shops.

Vintage. Con un aire entre nórdico y vintage, estas tres piezas colgantes se adaptan a todos los espacios colocándolas solas o combinadas. De estilo años 60, mantienen la elegancia y la simplicidad formal y su iluminación directa y focalizada la hace perfecta para hoteles, restaurantes y tiendas.

Vintage. Dotées d'un air à la fois nordique et vintage, ces trois pièces suspendues s'adaptent à tous les espaces, seules ou combinées. De style années soixante, ces modèles élégants aux formes simples offrent un éclairage direct et focalisé qui les rendent idéaux dans l'hôtellerie, la restauration et le commerce.



00-5940-CI-CI ■

3 × LED CREE 35W
3000K 3150 lm



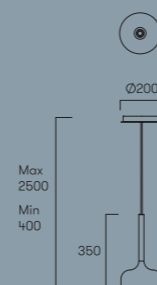
Finishing | Acabados | Finitions

■ CI Brown | Marrón | Marron + ■ O6 Copper | Cobre | Cuivre

Materials | Materiales | Matériaux

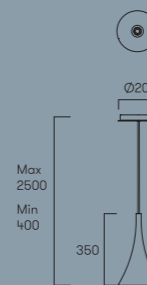
■ ST Steel | Acero | Acier

■ PMMA Diffuser material PMMA | Material difusor PMMA | Matériau diffusant PMMA



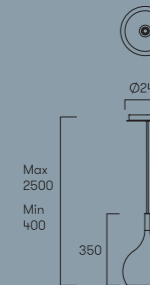
00-5939-CI-CI ■

1 × LED CREE 11W
3000K 1050 lm



00-5938-CI-CI ■

1 × LED CREE 11W
3000K 1050 lm



00-5937-CI-CI ■

1 × LED CREE 11W
3000K 1050 lm



Nahtrang Disseny

Spin

Spin

Kindness. Its dual circular structure of silk wrapped around a central void makes it unique and singular. It is a classic piece in which forms and materials contrast to provide warmth in any space.

Amabilidad. Su doble estructura circular de seda encintada con un vacío central, la hace única y singular. Se trata de una pieza clásica en la que contrastan formas y materiales que aporta calidez en el espacio donde se coloca.

Amabilité. Sa double structure circulaire en soie avec un trou central la rend unique et singulière. C'est une pièce classique dans laquelle contrastent des formes et des matériaux qui apportent de la chaleur dans l'espace où elle est placée.

Finishing | Acabados | Finitions

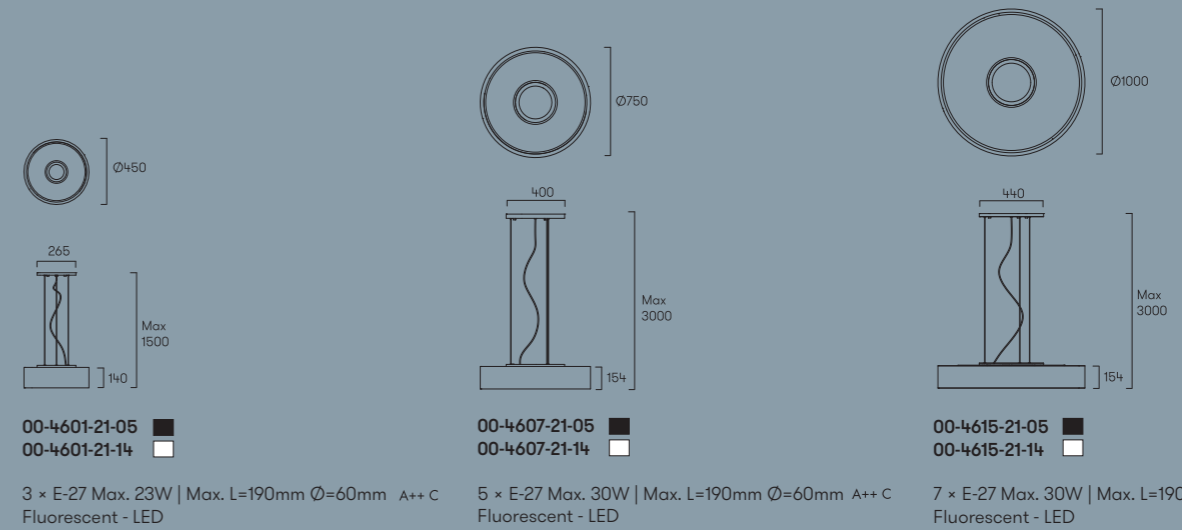


Finishing | Acabados | Finitions

- 05 Black | Negro | Noir
- 14 White | Blanco | Blanc
- 21 Chrome | Cromo | Chrome

Materials | Materiales | Matériaux

- PMMA Diffuser material PMMA | Material difusor PMMA
- DIF PMMA | Matériau diffusant PMMA
- ST Steel | Acero | Acier
- TEXTIL Fabric | Tela | Tissu



00-4601-21-05 ■
00-4601-21-14 □
3 × E-27 Max. 23W | Max. L=190mm Ø=60mm A++ C
Fluorescent - LED

00-4607-21-05 ■
00-4607-21-14 □
5 × E-27 Max. 30W | Max. L=190mm Ø=60mm A++ C
Fluorescent - LED

00-4615-21-05 ■
00-4615-21-14 □
7 × E-27 Max. 30W | Max. L=190mm Ø=60mm A++ C
Fluorescent - LED

Collection

Illuminates your spaces alongside the other pieces that comprise this collection.

Colección

Ilumina tus espacios con el resto de piezas que componen esta colección.

Collection

Éclairiez vos espaces avec le reste des pièces de cette collection.



Ceiling
Techo
Plafond p. 258



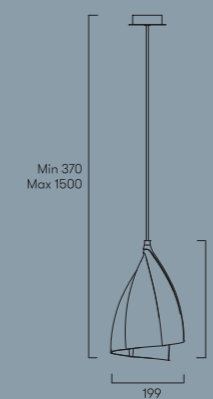
Tulip

Mysterious. The plant-like morphology of this luminaire explores organic forms. The spiral connection of its petals creates a mysteriously asymmetrical yet harmonic and natural piece.

Misteriosa. La morfología vegetal de esta luminaria en suspensión explora las formas orgánicas. La conexión en espiral de sus pétalos crea una figura misteriosamente asimétrica pero armónica y natural al mismo tiempo.

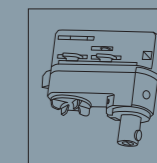
Mystérieux. La morphologie végétale de ce luminaire en suspension explore les formes organiques. La disposition en spirale de ses pétales crée une figure mystérieusement asymétrique qui reste cependant harmonieuse et naturelle.

Finishing | Acabados | Finitions



00-4416-05-23 ■
00-4416-78-03 □

1 x E-27 Max. 23W Max. L=150mm Ø=60mm A++ C
Fluorescent - LED



71-2232-14-14
Track Connector |
Conector de Carril |
Connecteur de Rail



Finishing | Acabados | Finitions

■ 05 Black Negro Noir	+	■ 23 Golden Dorado Doré
□ 78 White lacquered Lacado blanco Laqué en blanc	+	■ 03 Grey Gris Gris

Materials | Materiales | Matériaux

ABS ABS | ABS | ABS

Estudi Ribaudí

Tulip



Benedito Design

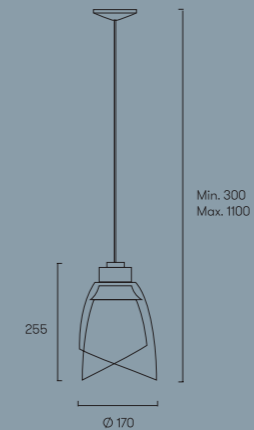
Twins

Twins

Levity. The simple geometry of this luminaire features an audacious opening in the side of its components to lend it a certain vibrancy. This glass-on-metal dual-material pendant lamp brings a sensation of levity to the atmosphere, giving the space a certain singularity and distinction.

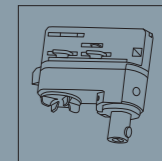
Levedad. Esta luminaria de geometría sencilla se caracteriza por un corte audaz en el perfil lateral de sus piezas que le imprime dinamismo. Este colgante bi-material, vidrio sobre metal, aporta a la atmósfera una sensación de levedad que dota al espacio de singularidad y distinción.

Légèreté. Ce luminaire à la géométrie simple se caractérise par une coupe audacieuse dans le profil latéral de ses pièces qui lui apporte du dynamisme. Cette suspension bi-matière, du verre sur du métal, confère à l'atmosphère une sensation de légèreté qui donne à l'espace un caractère différent et singulier.



00-0087-N3-F9

1 x E-27 Max. 100W | Max. L=150mm Ø=60mm A++ C
Fluorescent - LED



71-2232-14-14
Track Connector |
Conector de Carril |
Connecteur de Rail



Finishing | Acabados | Finitions

N3 Grey texture | Gris textura |
Gris à effet de texture

Materials | Materiales | Matériaux

ST Steel | Acero | Acier

GLASS OPALS Diffuser material optic glass | Material difusor cristal óptico | Matériau diffusant verre optique
DIF

GLASS TRANS Diffuser material transparent glass | Material difusor cristal transparente | Matériau diffusant verre transparent
DIF



Benedito Design

Leila

Leila

Neutrality. With a classic design, this pendant lamp can be installed individually or with a dual lighting system. Its metallic structure in a chrome or satin aluminium finish and white cloth shade fits perfectly into any space.

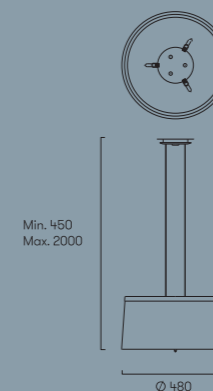
Neutralidad. De diseño clásico, esta luminaria de suspensión puede instalarse de manera individual o con un sistema de doble iluminación. Su estructura metálica en acabado cromo y aluminio satinado y su pantalla de tela en color blanco se integra fácilmente en los espacios.

Neutralité. De ligne classique, ce luminaire en suspension peut être installé seul ou en double éclairage. Doté d'une structure métallique en aluminium satiné à finition chromée et d'un abat-jour blanc, il s'intègre facilement dans tous les espaces.



00-2407-AG-14

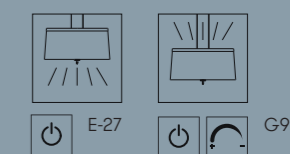
3 × E-27 Max. 23W | Max. L=180mm Ø=60mm
Fluorescent - LED
+ 3 × G9 Max. 40W OSRAM included A++ C



Min. 680
Max. 1000

20-2407-AG-14

4 × E-14 Max. 15W | Max. L=145mm Ø=60mm
Fluorescent - LED
+ 4 × G9 Max. 40W OSRAM included A++ C



Min. 450
Max. 2000

Ø 480

240

00-2407-AG-14

3 × E-27 Max. 23W | Max. L=180mm Ø=60mm
Fluorescent - LED
+ 3 × G9 Max. 40W OSRAM included A++ C



Finishing | Acabados | Finitions

14 White | Blanc | Blanc

AG Aluminium with chrome | Aluminio con cromo | Aluminium avec chrome

Materials | Materiales | Matériaux

PMMA Diffuser material PMMA | Material difusor PMMA | Matériau diffusant PMMA

ST Steel | Acero | Acier

TEXTIL SHADE Shade material fabric | Material pantalla tela | Matériels Abat-jour tissu

Collection

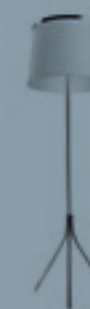
Illuminates your spaces alongside the other pieces that comprise this collection.

Colección

Ilumina tus espacios con el resto de piezas que componen esta colección.

Collection

Éclairer vos espaces avec le reste des pièces de cette collection.



Floor
Pie
Pied p. 240



Josep Patsí

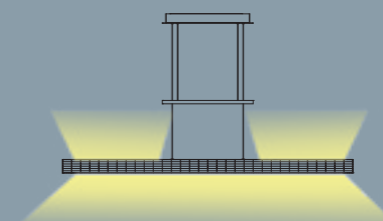
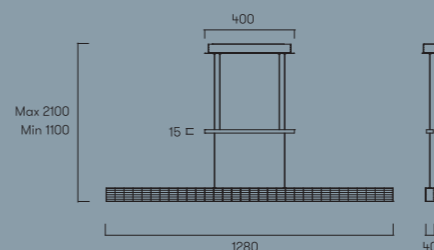
Stream

Stream

Slenderness. The linear design of this lamp makes it appear lightweight and slender. It owes its personality to the interspersed ripples that provide the texture on its lateral surfaces.

Esbeltez. El formato lineal de su diseño dota a esta lámpara de suspensión de una sensación de ligereza y esbeltez. Su personalidad se debe a las ondulaciones entrecortadas que crean la textura de sus superficies laterales.

Sveltezza. Le format linéaire de son design dote cette suspension d'une sensation de légèreté et de sveltesse. Ce modèle doit sa personnalité aux ondulations entrecroisées qui créent la texture de ses surfaces latérales.



00-2924-BW-M1V1

LED 27,5W (Down) 2640 lm
LED 12,5W (Up) 1200 lm A++ A
3000K



Finishing | Acabados | Finitions

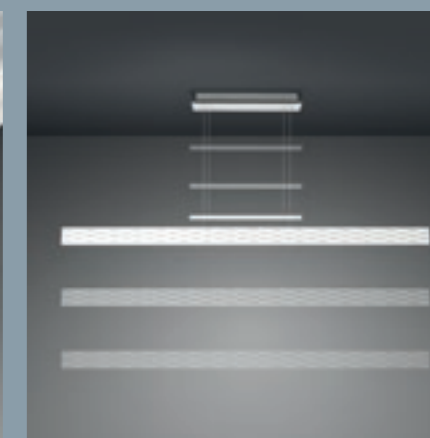
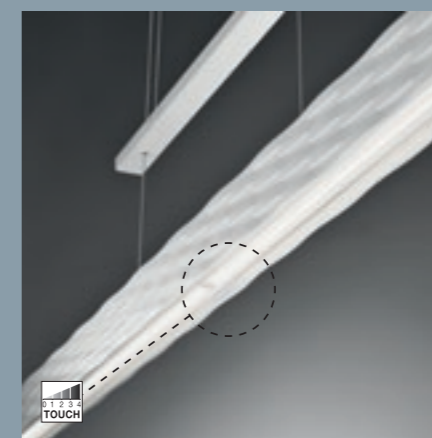
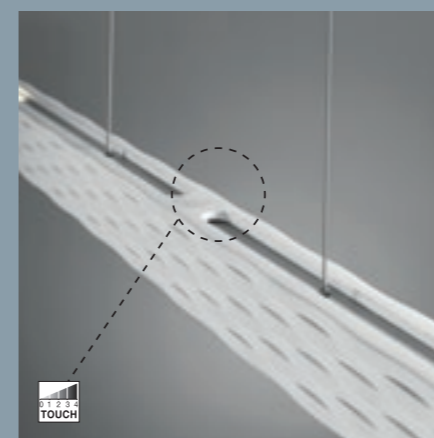
BW Matt white | Blanco mate | Blanc mate

Materials | Materiales | Matériaux

AL Aluminium | Aluminio | Aluminium

PUR Polyurethane | Poliuretano | Polyuréthane

PMMA Diffuser material PMMA | Material difusor
DIF PMMA | Matériau diffusant PMMA



Independent paired lighting system | Sistema de doble iluminación independiente | Système à double éclairage indépendant

Collection

Illuminates your spaces alongside the other pieces that comprise this collection.

Colección

Ilumina tus espacios con el resto de piezas que componen esta colección.

Collection

Éclairiez vos espaces avec le reste des pièces de cette collection.



Wall
Pared
Mural p. 184



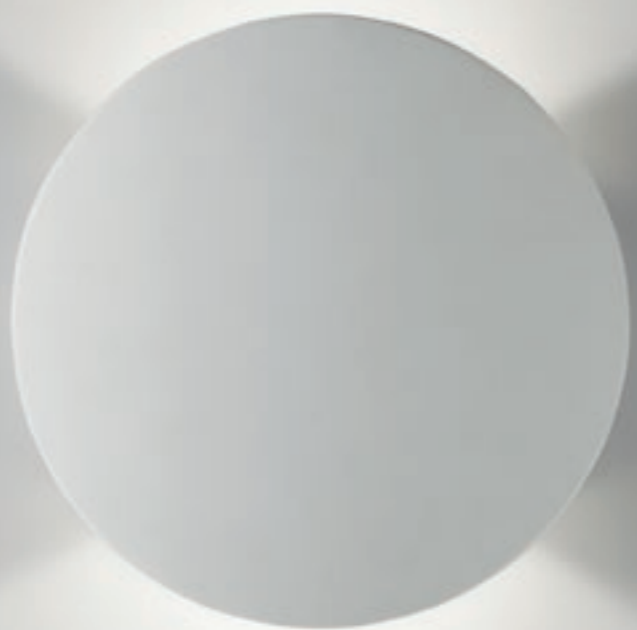
<u>Wall</u>	Prime	134	Talk	172
<u>Pared</u>	Invisible	140	Emy	175
<u>Mural</u>	Flavia	144	Igloo	178
	Big Bang	148	Skata	180
	Bend	152	Suite	182
	Rizz	156	Stream	184
	Eos	160	Wave	186
	Hall	164	Flat	188
	Surf	168		



Josep Patsí

Prime





Josep Patsí
Prime



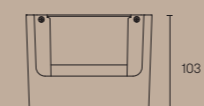
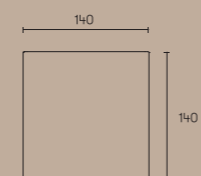


Prime

Power. It is a fundamental and necessary piece in any interior design project because its simple geometry easily integrates into any space. It combines simplicity and delicacy of form with the most powerful LED lighting available on the market.

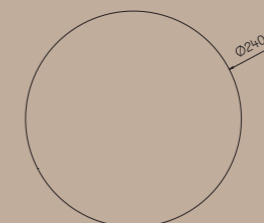
Potencia. Es una pieza básica y necesaria en todo proyecto de interior por su geometría simple y fácil de integrar en cualquier espacio. Combina la simplicidad y la suavidad de sus formas con la iluminación led más potente y disponible del mercado.

Puissance. C'est une pièce de base nécessaire dans tout projet d'intérieur de par sa géométrie simple et facile à intégrer dans tous les espaces. Il allie la simplicité et la douceur de ses formes avec l'éclairage LED le plus puissant disponible sur le marché.



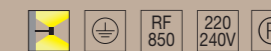
05-5956-BW-BW
(Mains dimming)*

1 x LED 40W A++ A
4000 lm 3000K



05-5957-BW-BW
(Mains dimming)*

2 x LED 20W A++ A
4000 lm 3000K



Finishing | Acabados | Finitions

BW Matt white | Blanco mate | Blanc mate

Materials | Materiales | Matériaux

AL Aluminium | Aluminio | Aluminium

* Mains dimmer compatibility at www.leds.c4.com (Products & Downloads)

* Compatibilidad con reguladores corte de fase en www.leds-c4.com (Productos & Descargas)

* Compatible avec des variateurs en coupure de phase que vous pouvez consulter www.leds-c4.com (Produits & Téléchargements)



140

Francesc Vilaró

Invisible



141



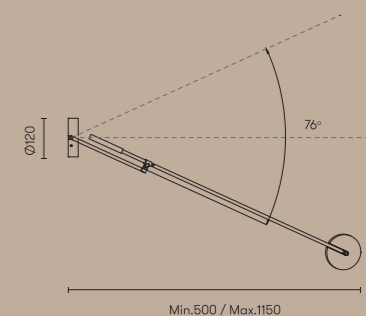
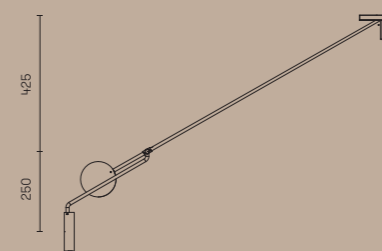
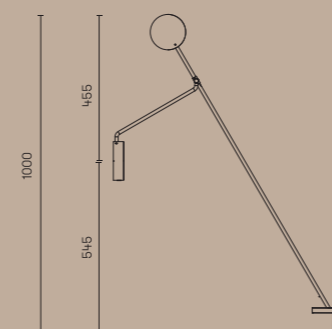


Invisible

Authenticity. The unique, timeless and versatile design of this collection means it can be adapted to suit all types of spaces. The flexibility of its parts enables the light to be controlled easily and directed wherever it is needed.

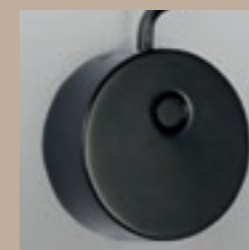
Autenticidad. El diseño propio, atemporal y versátil permite que esta colección se adapte a todo tipo de espacios. La flexibilidad de sus piezas permite controlar fácilmente la luz y dirigirla donde sea necesario.

Authenticité. Le design épuré, intemporel et polyvalent permet à cette collection de s'adapter à tous les types d'espaces. La flexibilité des différentes pièces permet de contrôler facilement la lumière et de la diriger en cas de besoin.



05-5693-05-05 ■

LED 9W 765lm 3000K
A++ A



143

Finishing | Acabados | Finitions

05 Black | Negro | Noir

Materials | Materiales | Matériaux

AL Aluminium | Aluminio | Aluminium

PMMA Diffuser material PMMA | Material difusor PMMA | Matériau diffusant PMMA

Collection

Illuminates your spaces alongside the other pieces that comprise this collection.

Colección

Ilumina tus espacios con el resto de piezas que componen esta colección.

Collection

Éclairer vos espaces avec le reste des pièces de cette collection.



Pendant
Suspensión
Suspension p. 48

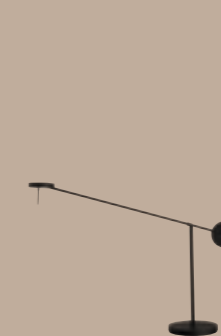


Table
Sobremesa
Table p. 192



Floor
Pie
Pied p. 216



Benedito Design

Flavia



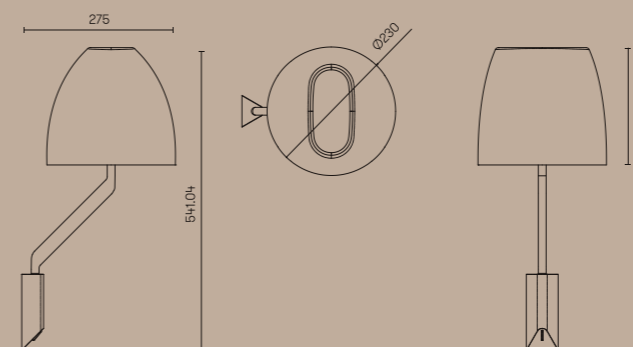


Flavia

Distinction. With an unforgettable design that stands out from the rest, the shape of this luminaire is based on an audacious gesture, a touch of distinction, making it ideal for residential and hotel environments.

Distinción. Con un diseño para recordar y diferenciarse, la forma de esta luminaria se basa en un gesto audaz, en un toque de distinción, pensada para entornos residenciales y hoteleros.

Distinction. Avec un design différent dont on se souviendra, la forme de ce luminaire part d'un geste audacieux, d'une touche de classe, conçue pour les environnements résidentiels et hôteliers.



Finishing | Acabados | Finitions

21 Chrome | Cromo | Chrome

Materials | Materiales | Matériaux

PMMA Diffuser material PMMA | Material difusor PMMA
DIF PMMA | Matériau diffusant PMMA

ZAMAK Zamak | Zamak | Zamak

05-3686-21-M1

1 x E-27 Max. 18W |
Max. L=125mm Ø=78mm
A++ C
Fluorescent - LED

Collection

Illuminates your spaces alongside the other pieces that comprise this collection.

Colección

Ilumina tus espacios con el resto de piezas que componen esta colección.

Collection

Éclairiez vos espaces avec le reste des pièces de cette collection.



Table
Sobremesa
Table p. 196

Floor
Pie
Pied p. 220



Francesc Vilaró

Big Bang



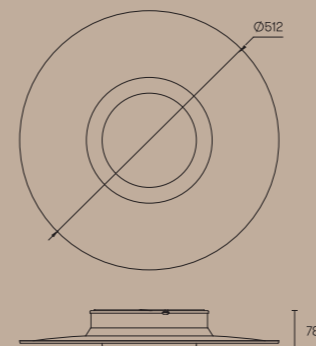


Big Bang

Sensuality. This appealing wall lamp with LED technology is a sensory explosion of light. The indirect light generated by this luminaire is reflected onto gold-coloured metal creating a sensual halo of light that produces different effects by day or night.

Sensualidad. Este sugerente aplique con tecnología led es un estallido sensorial de luz. La luz indirecta que genera esta luminaria se refleja sobre una pieza de metal dorado que crea un halo lumínico sensual produciendo diferentes efectos de día o de noche.

Sensualité. Cette applique suggestive dotée de la technologie LED est une explosion sensorielle de lumière. La lumière indirecte générée par ce luminaire est réfléchié sur une pièce de métal dorée qui crée un halo lumineux sensuel produisant différents effets de jour ou de nuit



05-5085-BW-BW

LED 9W (Back) | 765 lm 3000K

+

LED 13,5W (Front) A++ A | 1.147 lm 3000K



Finishing | Acabados | Finitions

BW Matt white
| Blanco mate |
Blanc mate

+ **27** Matt satin
finished brass |
Latón satinado
mate | Laiton
satiné mat

Materials | Materiales | Matériaux

AL Aluminium | Aluminio | Aluminium

PMMA Diffuser material PMMA | Material difusor
 DIF PMMA | Matériau diffusant PMMA



Benedito Design

Bend





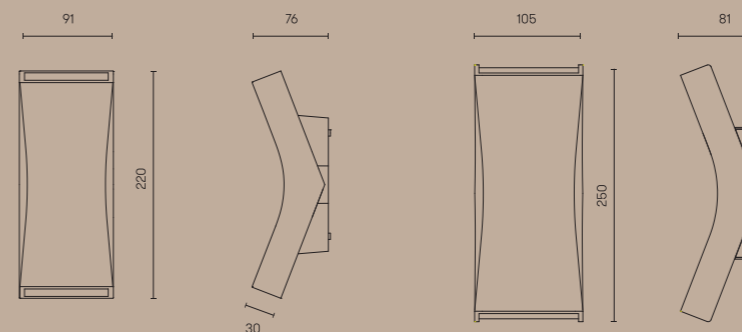
Bend

Functionality. With forceful straight lines, this front-facing wall lamp is focused in the centre and expands outwards to increase the dimensions of the two windows at the sides. The inclination of these windows controls the distribution of the light halo to give it a strong personality.

Funcionalidad. De formas lineales y contundentes, este aplique frontal se ciñe en el centro y se expande hacia los límites para incrementar la dimensión de las dos ventanas situadas en los extremos. La inclinación de estas orienta la difusión del halo luminoso dotándola de una fuerte personalidad.

Fonctionnalité. Aux formes linéaires et contundentes, cette applique frontale se tient au centre et s'élargit vers les limites pour augmenter la taille des deux fenêtres situées aux extrémités. L'inclinaison de celles-ci oriente la diffusion du halo lumineux en lui donnant une forte personnalité.

Finishing | Acabados | Finitions



05-4394-78-M1V1
05-4394-AH-M1V1

2 x LED CREE 4,5W |
A++ A
880 lm 3000K



05-5954-BW-M1 (Mains dimming)*
05-5954-Z5-M1 (Mains dimming)*

2 x LED CREE 9W |
A++ A
1920 lm 3000K
220-240V



Finishing | Acabados | Finitions

BW Matt white | Blanco mate | Blanc mate

78 White lacquered | Lacado blanco | Laqué en blanc

AH Ecobright aluminium | Aluminio ecobright | Aluminium Ecobright

Z5 Anthracite Grey | Gris Antracita | Gris Anthracite

Materials | Materiales | Matériaux

AL Aluminium | Aluminio | Aluminium

PMMA Diffuser material PMMA | Material difusor PMMA

* Mains dimmer compatibility at www.leds.c4.com [Products & Downloads]

* Compatibilidad con reguladores corte de fase en www.leds.c4.com [Productos & Descargas]

* Compatible avec des variateurs en coupure de phase que vous pouvez consulter www.leds.c4.com [Produits & Téléchargements]



Ramón Valls

Rizz





Rizz

Integration. The various finishes and measurements of these luminaires facilitates their incorporation into any space regardless of its decorative style, filling it with different visual and lighting appearances.

Integración. Los diferentes acabados y medidas de estas luminarias permiten su mejor incorporación en los espacios, independientemente de su estilo decorativo, llenándolos con diversos aspectos visuales y lumínicos.

Intégration. Les différentes finitions et tailles de ces luminaires permettent une meilleure intégration dans les espaces, quel que soit leur style décoratif, en leur apportant différents aspects visuels d'éclairage.

Finishing | Acabados | Finitions

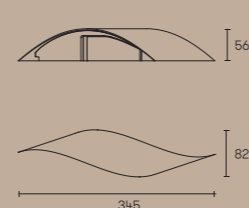


Finishing | Acabados | Finitions

- AF** Satin aluminium | Aluminio satinado | Aluminium satiné
- 27** Matt satin finished brass | Latón satinado mate | Laiton satiné mat
- BW** Matt white | Blanco mate | Blanc mate
- 06** Copper | Cobre | Cuivre

Materials | Materiales | Matériaux

- AL Aluminium | Aluminio | Aluminium
- PMMA Diffuser material PMMA | Material difusor
- DIF PMMA | Matériau diffusant PMMA



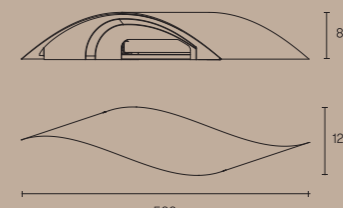
- 05-1819-AF-AF
- 05-1819-27-27
- 05-1819-BW-BW
- 05-1819-06-06

LED CREE 6W |
A++ A
510 lm 3000K

05-1817-AF-AF

1 x R7s L=78 Max. 80W |
A++ C
OSRAM included

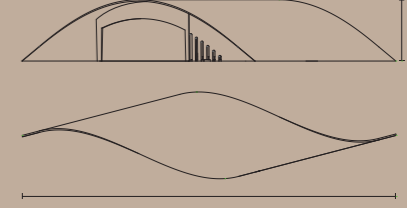
100
240V



- 05-1822-AF-AFV1
- 05-1822-27-27V1
- 05-1822-BW-BWV1
- 05-1822-06-06V1

LED CREE 18,3W |
A++ A
1380 lm 3000K

100
240V



- 05-5969-BW-BW 100
240V
- 05-5969-AF-AF 100
240V
- 05-6016-BW-BW (Mains dimming)* 220
240V
- 05-6016-AF-AF (Mains dimming)* 220
240V

LED CREE 30.7W
2300 lm 3000K

* Mains dimmer compatibility at www.leds-c4.com (Products & Downloads)

* Compatibilidad con reguladores corte de fase en www.leds-c4.com (Productos & Descargas)

* Compatible avec des variateurs en coupure de phase que vous pouvez consulter www.leds-c4.com (Produits & Téléchargements)



Its special design allows for multiple combinations. Su especial diseño permite múltiples combinaciones. Son design spécial permet de nombreuses combinaisons.

Connection scheme.
Esquema de conexión.
Schéma de connexion.



Josep Patsí

Eos





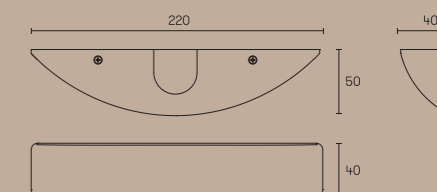
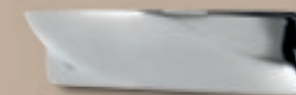
Eos



Cosy. This light takes its name from the Greek goddess who announced the sunrise. Designed for use in a domestic environment and in locations such as hotels, bars and restaurants because of its soft, sinuous forms combined in a horizontal rectangle and its bathroom-light effect.

Acogedora. Esta luminaria tiene el nombre de la diosa griega que anunciaba la salida del sol. Diseñada para utilizarse tanto en un entorno doméstico como en hospitalities por la sinuosa suavidad de sus formas sintetizada en un rectángulo horizontal y por su efecto de luz de baño.

Accueillant. Ce luminaire arbore le nom de la déesse grecque qui annonçait le lever du soleil. Il est conçu pour être utilisé tant en milieu résidentiel que dans l'hôtellerie, grâce à sa ligne galbée formant un rectangle horizontal et à son effet lèche-murs.

Finishing | Acabados | Finitions




05-5078-BW-BWV1 
05-5078-21-21V1 

LED x 4,5W |
A++ A
500 lm 3000K





Finishing | Acabados | Finitions

 BW Matt white | Blanco mate | Blanc mate

 21 Chrome | Cromo | Chrome

Materials | Materiales | Matériaux

 AL Aluminium | Aluminio | Aluminium

 PMMA Diffuser material PMMA | Material difusor PMMA | Matériau diffusant PMMA



It includes 2 interchangeable diffusers.
Incluye dos difusores intercambiables.
Comprend deux diffuseurs interchangeables.



Nahtrang Disseny

Hall



Hall

Simplicity. With a contemporary style, this wall lamp is the centrepiece of a family that is designed and created to meet the needs of hotels. Its careful lines and shapes, and square cross-section, make this luminaire a unique piece.

Simplicidad. De diseño contemporáneo, este aplique es el núcleo de una familia ideada y creada para cubrir las necesidades de los hoteles. Sus líneas y formas cuidadas, y de sección cuadrada, hacen a esta luminaria una pieza única.

Simplicité. Au design contemporain, cette applique est au cœur d'une gamme conçue et pensée pour répondre aux besoins des hôtels. Ses lignes, ses formes soignées, et sa section carrée font de ce luminaire une pièce unique.

1-Step

Choose the structure in the finish that best suits you. Elige la estructura en el acabado que más te guste. Choisissez la structure dans la finition que vous préférez.



+

2-Step

Select the shape, size and finish of the shade. You can see our recommendations on the following pages. Elige la forma, tamaño y acabado de la pantalla. Verás nuestras recomendaciones en las páginas siguientes. Choisissez la forme, la dimension et la finition de l'abat-jour. Vous trouverez nos recommandations dans les pages suivantes.



3-Step

Your lamp is now ready! ¡Tu lámpara está lista! Votre lampe est prête!



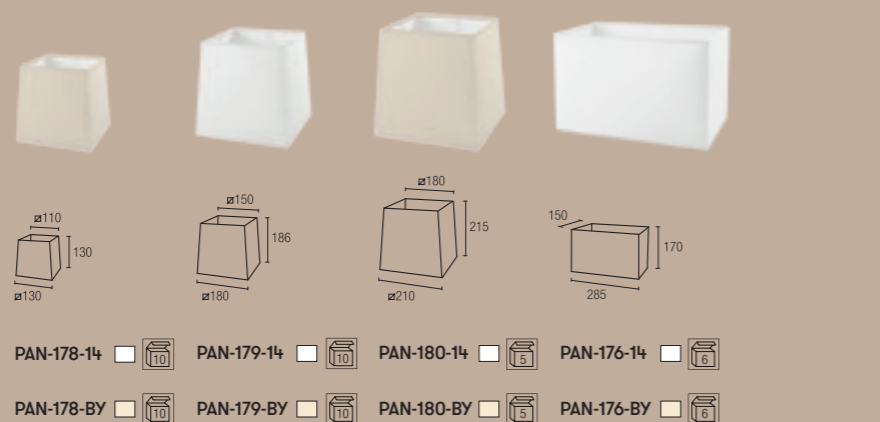
Round shades Pantallas redondas Abat-jour ronds



Finishing | Acabados | Finitions

- 14 White | Blanco | Blanc
- BY Beige | Beige | Beige
- AJ Opera grey | Gris ópera | Gris opéra

Squared shades Pantallas cuadradas Abat-jour carrés



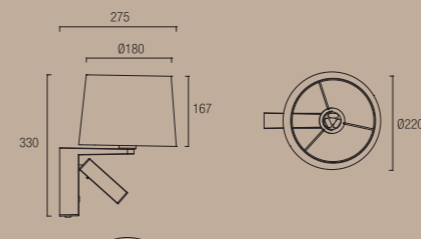
Finishing | Acabados | Finitions

- 14 White | Blanco | Blanc
- BY Beige | Beige | Beige

LEDS-C4 offers you the possibility to entirely customize the shades, choosing the shape, size, material and the most appropriate design for each atmosphere. |

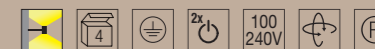
LEDS-C4 te ofrece la posibilidad de personalizar totalmente las pantallas, eligiendo la forma, el tamaño, el material y el acabado más idóneo para cada ambiente. |

LEDS-C4 vous offre la possibilité de personnaliser totalement les abat-jour en choisissant la forme, la dimension, la matière et la finition qui convient le mieux à chaque espace.



05-1941-BW-82 + PAN
05-1941-81-82 + PAN

1 x E-27 Max. 60W |
Max. L=130mm Ø=60mm
Halogen - Fluorescent - LED
1 x LED CREE 3W A++ c
162 lm 3000K



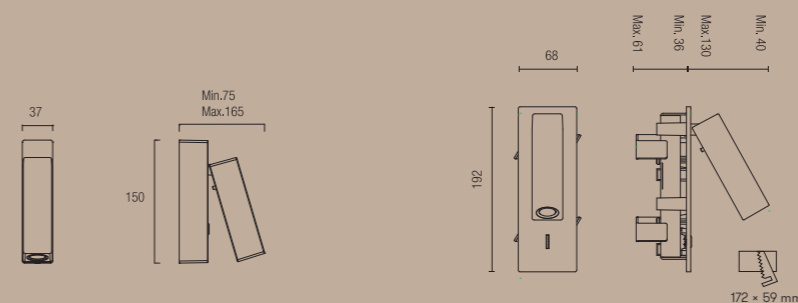
Finishing | Acabados | Finitions

- BW Matt white | Blanco mate | Blanc mate
- 81 Satin nickel | Níquel satinado | Nickel satiné

Materials | Materiales | Matériaux

Aluminium | Aluminio | Aluminium

Shade material fabric | Material pantalla tela | Matériels abat-jour tissu



05-1940-BW-BW
05-1940-81-81

1 x LED CREE 3W A++ c
162 lm 3000K

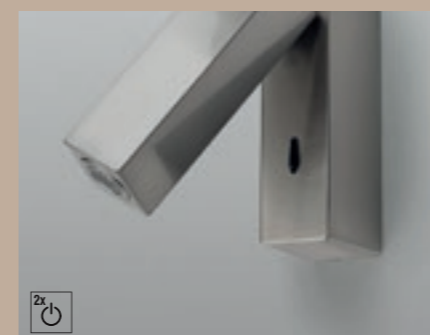
05-4787-BW-BW
05-4787-81-81

1 x LED CREE 3W A++ c
162 lm 3000K

71-4787-AV-AV

Recessing kit for brick wall
Kit para empotrar en pared de obra
Kit pour encastrer au mur

167



Finishing | Acabados | Finitions

- BW Matt white | Blanco mate | Blanc mate
- 81 Satin nickel | Níquel satinado | Nickel satiné

Materials | Materiales | Matériaux

Aluminium | Aluminio | Aluminium

Zamak | Zamak | Zamak

Collection

Illuminates your spaces alongside the other pieces that comprise this collection.

Colección

Ilumina tus espacios con el resto de piezas que componen esta colección.

Collection

Éclairer vos espaces avec le reste des pièces de cette collection.



Table
Sobremesa
Table p. 204



Floor
Pie
Pied p. 228



Josep Patsí

Surf





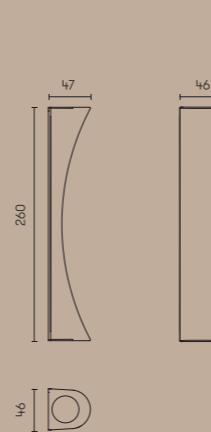
Surf




Diversity. These lamps can be installed individually or in multiple compositions in response to the needs of each space. It has the capacity to fill a space and generate a variety of visual and lighting results.

Diversidad. Estas lámparas pueden instalarse de manera individual o formando múltiples composiciones dando respuesta a las necesidades de cada espacio. Tienen la capacidad de llenar el espacio generando diversos aspectos visuales y lumínicos.

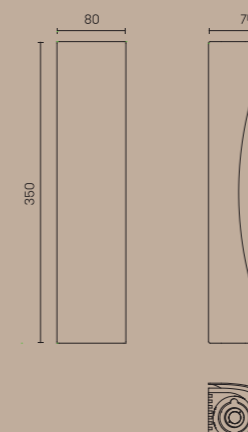
Diversité. Ces lampes peuvent être installées individuellement où former plusieurs compositions pour répondre aux besoins de chaque espace. Elles ont la capacité de remplir l'espace en créant divers aspects visuels d'éclairage.




Finishing | Acabados | Finitions



05-5077-BW-BWV1 
 05-5077-21-21V1 
 05-5077-06-06V1 

2 LED x 4,5W | A++ A
 1000 lm 3000K






05-5968-BW-BW (Mains dimming)* 
 05-5968-21-21 (Mains dimming)* 
 05-5968-06-06 (Mains dimming)* 


2 x LED 10W | A++ A
 2000 lm 3000K





Finishing | Acabados | Finitions

-  **21** Chrome | Cromo | Chrome
-  **BW** Matt white | Blanco mate | Blanc mate
-  **06** Cooper | Cobre | Cuivre

Materials | Materiales | Matériaux

 Aluminium | Aluminio | Aluminium

 Diffuser material PMMA | Material difusor PMMA
 PMMA | Matériau diffusant PMMA

* Mains dimmer compatibility at www.leds.c4.com (Products & Downloads)

* Compatibilidad con reguladores corte de fase en www.leds-c4.com (Productos & Descargas)

* Compatible avec des variateurs en coupure de phase que vous pouvez consulter www.leds-c4.com (Produits & Téléchargements)



It includes 2 interchangeable diffusers.
 Incluye dos difusores intercambiables.
 Comprend deux diffuseurs interchangeables.



Nahtrang Disseny

Talk



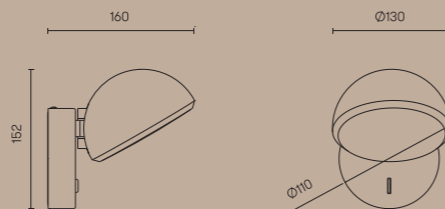
Talk

Vibrancy. Highly singular geometric pieces made from 100% recyclable aluminium that enable the whole piece to act as a large heat dissipater, noticeably lengthening LED life.

Dinamismo. Piezas geométricas muy singulares realizadas con aluminio 100% reciclable que permite que toda la pieza en sí actúe como un gran disipador del calor alargando notablemente la vida del led.

Dynamisme. Pièces géométriques très singulières conçues en aluminium 100 % recyclable qui permettent à l'ensemble de la pièce elle-même d'agir comme un grand dissipateur de chaleur prolongeant de manière significative la durée de vie de la LED.

Finishing | Acabados | Finitions



05-5458-BW-F9
05-5458-Z5-F9

LED CREE 6,5W |
A++ A
695 lm 2700K



Finishing | Acabados | Finitions

BW Matt white | Blanco mate | Blanc mate

Z5 Anthracite Grey | Gris Antracita | Gris Anthracite

Materials | Materiales | Matériaux

AL Aluminium | Aluminio | Aluminium

GLASS Diffuser material glass | Material difusor
 DIF Cristal | Matériau diffusant Verre

Collection

Illuminates your spaces alongside the other pieces that comprise this collection.

Colección

Ilumina tus espacios con el resto de piezas que componen esta colección.

Collection

Éclairer vos espaces avec le reste des pièces de cette collection.



Pendant
Suspensión
Suspension p. 82



Table
Sobremesa
Table p. 210



Francesc Vilaró

Emy

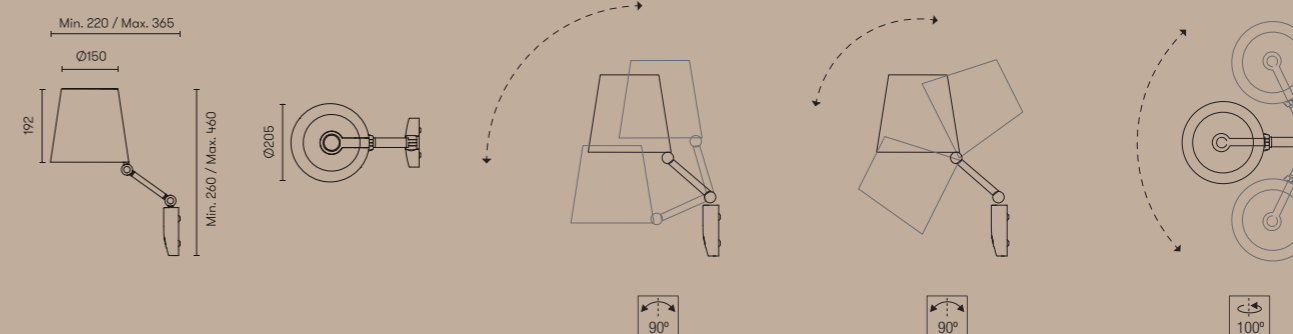


Emy

Elegance. This is an extensive and versatile range for contract environments where the strength of the materials and its ability to create specific atmospheres are essential. It is also ideal for installation in classic but modern spaces.

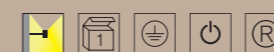
Elegancia. Se trata de una colección amplia y versátil orientada para entornos contract por la resistencia de sus materiales y por su capacidad de generar ambientes específicos. También está ideada para instalar en espacios clásicos pero modernos.

Élégance. C'est une collection vaste et polyvalente destinée aux milieux professionnels de par la résistance de ses matériaux et de sa capacité à générer des ambiances spécifiques. Elle est également conçue pour être installée dans des espaces classiques, mais modernes.



05-4409-21-12 ■

1 x E-14 Max. 15W |
Max. L=100mm Ø=45 mm
A++ C
Fluorescent - LED



Finishing | Acabados | Finitions

21 Chrome | Cromo | Chrome

12 Smoked acrylic diffuser | Difusor acrílico fumé | Diffuseur acrylique fumé

Materials | Materiales | Matériaux

AL Aluminium | Aluminio | Aluminium

PMMA Diffuser material PMMA | Material difusor PMMA | Matériau diffusant PMMA

PC Shade material Polycarbonate | Material pantalla Polycarbonato | Matériels Abat-jour Polycarbonate

Collection

Illuminates your spaces alongside the other pieces that comprise this collection.

Colección

Ilumina tus espacios con el resto de piezas que componen esta colección.

Collection

Éclairiez vos espaces avec le reste des pièces de cette collection.



Pendant
Suspensión
Suspension p. 95

Table
Sobremesa
Table p. 212

Floor
Pie
Pied p. 234

Benedito Design

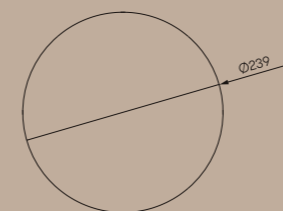
Igloo

Igloo

Delicacy. Available in two different sizes, this steel luminaire with a matt white finish and opal PMMA diffuser produces a sensual and delicate source of light.

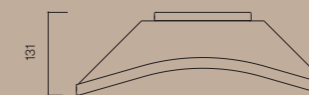
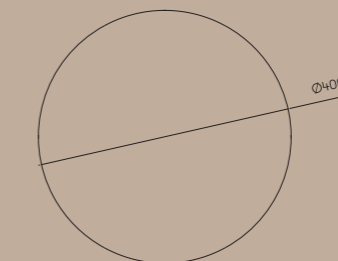
Delicadeza. Disponible en dos medidas diferentes, esta luminaria de estructura de acero, acabados en blanco mate y difusor PMMA opal se presenta como un punto de luz sensual y delicado.

Délicatesse. Disponible en deux formats différents, ce luminaire doté d'une structure en acier, de finitions en blanc mat et d'un diffuseur opalin en PMMA, se présente comme un point lumineux à la fois sensuel et délicat.



05-5276-BW-M1 (Mains dimming)*

LED 10W |
A++ A
1.000 lm 2700K



05-5277-BW-M1 (Mains dimming)*

LED OSRAM 32W |
A++ A
3.200 lm 2700K



Finishing | Acabados | Finitions

BW Matt white | Blanco mate | Blanc mate

Materials | Materiales | Matériaux

ST Steel | Acero | Acier

PMMA Diffuser material PMMA | Material difusor PMMA | Matériau diffusant PMMA

* Mains dimmer compatibility at www.leds.c4.com (Products & Downloads)

* Compatibilidad con reguladores corte de fase en www.leds.c4.com (Productos & Descargas)

* Compatible avec des variateurs en coupure de phase que vous pouvez consulter www.leds.c4.com (Produits & Téléchargements)

Collection

Illuminates your spaces alongside the other pieces that comprise this collection.

Colección

Ilumina tus espacios con el resto de piezas que componen esta colección.

Collection

Éclairer vos espaces avec le reste des pièces de cette collection.



Ceiling
Techo
Plafond p. 255

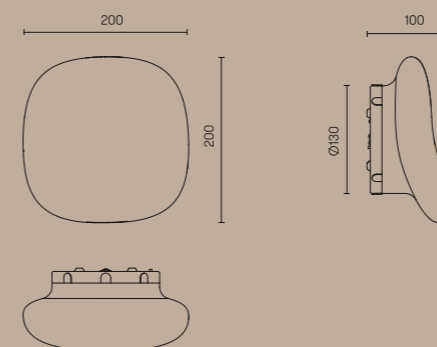


Skata

Versatility. Formed of organic pieces, this sophisticated composition is a reflection of ordered chaos. The inclination of its pieces adds a sensation of volume to the compositions that work whether or not they are switched on.

Versatilidad. Formado por piezas de formas orgánicas, este sofisticado juego de composición se presenta como un caos ordenado. La inclinación de las piezas añade una sensación de volumen en las composiciones que funcionan tanto cuando está encendida como apagada.

Polyvalence. Formé par des pièces aux formes organiques, ce jeu de composition sophistiqué se présente comme un chaos ordonné. L'inclinaison des pièces ajoute une sensation de volume dans les compositions qui fonctionnent à la fois quand elle est allumée ou éteinte.



05-4750-14-F9 ■

LED 4,3W |
A++ A
413 lm 3000K



Finishing | Acabados | Finitions

■ 14 White | Blanco | Blanc

Materials | Materiales | Matériaux

ST Steel | Acero | Acier

GLASS
OPAL
DIF Diffuser material triplex Opal glass |
Material difusor cristal opal triplex |
Materiau diffusant verre opal triplex

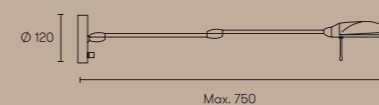


Its special design allows for multiple combinations.
Su especial diseño permite múltiples combinaciones.
Son design spécial permet de nombreuses combinaisons.

Connection scheme.
Esquema de conexión.
Schéma de connexion.

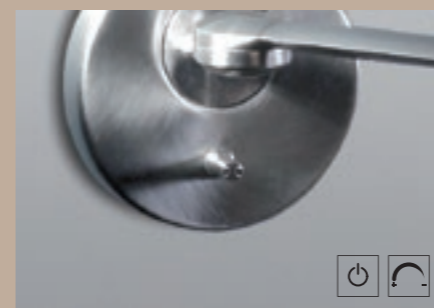
Francesc Vilaró

Skata



05-0380-81-B8
05-0380-BW-B8

1 x G9 Max. 75W |
A++ C | OSRAM included



Finishing | Acabados | Finitions

81 Satin nickel | Níquel satinado | Nickel satiné

BW Matt white | Blanco mate | Blanc mate

Materials | Materiales | Matériaux

ST Steel | Acero | Acier

GLASS MAT DIF Diffuser material matt glass | Material difusor vidrio mate | Matériau diffusant Verre

Benedito Design

Suite

Suite

Reinterpretation. A modern lamp that takes us back to classic forms with a minimalistic elliptical profile. An innovative solution has been applied to the joints to provide versatility of movement and keep all the constructive elements as low as possible.

Reinterpretación. Una lámpara actual que nos remite a las formas clásicas con un perfil elíptico de mínimas dimensiones. Para la versatilidad de sus movimientos, se ha aplicado una novedosa solución en las rótulas integrando todos los elementos constructivos con la menor altura posible.

Réinterprétation. Une lampe actuelle qui rappelle les formes classiques avec un profil elliptique aux dimensions minimales. Pour assurer la polyvalence de ses mouvements, une nouvelle solution a été appliquée dans les rotules intégrant tous les éléments de construction à la hauteur la plus basse possible.



Josep Patsí

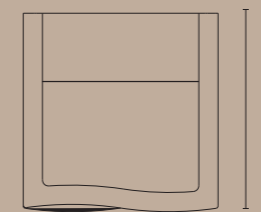
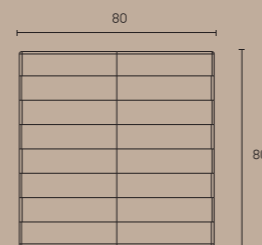
Stream

Stream

Slenderness. The independent double lighting system and the ability to adjust its height with a counterweight system make this light the perfect piece to place above long tables.

Esbeltez. El sistema de doble iluminación independiente y su altura regulable con un sistema de contrapeso, hacen de esta luminaria la pieza perfecta para colocar sobre mesas de largo formato.

Sveltezza. Grâce à son système de double éclairage indépendant et à sa hauteur réglable par contrepoids, ce luminaire est parfait au-dessus de tables grand format.

05-2924-BW-M3

LED CREE 4W |
A++ A
324 lm 3000K



Finishing | Acabados | Finitions

BW Matt white | Blanco mate | Blanc mate

Materials | Materiales | Matériaux

PUR Polyurethane | Poliuretano | Polyuréthane

AL Aluminium | Aluminio | Aluminium

PMMA Diffuser material PMMA | Material difusor
 DIF PMMA | Matériau diffusant PMMA

Collection

Illuminates your spaces alongside the other pieces that comprise this collection.

Colección

Ilumina tus espacios con el resto de piezas que componen esta colección.

Collection

Éclairer vos espaces avec le reste des pièces de cette collection.



Pendant
Suspensión
Suspension p. 130



Josep Patsí

Wave

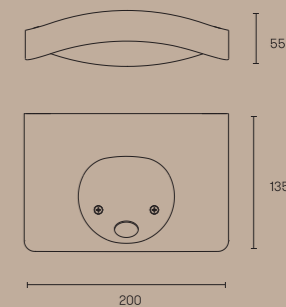
Wave




Multi-purpose. Due to the quantity and quality of the light it generates, this is a highly versatile indoor wall lamp. It is perfect for spaces that need a lot of light, while also offering visual comfort. The carefully studied position of its LED, which points towards the wall, fully harnesses the flow of the light and avoids glare.

Polivalencia. Por la cantidad y calidad de la luz que genera es un aplique de interior muy polivalente. Perfecto para espacios que necesiten mucha luz pero que ofrezcan al mismo tiempo confort visual. La estudiada posición de su led, enfocado hacia la pared, aprovecha todo el flujo lumínico y evita deslumbramientos.

Polyvalence. La quantité et la qualité de la lumière générée en font une applique d'intérieur très polyvalente. Parfaite pour les espaces qui ont besoin de beaucoup de lumière, mais qui offre en même temps un confort visuel. La position étudiée de sa LED, axée vers le mur, profite maximise tous les flux de lumière et empêche les éblouissements.

Finishing | Acabados | Finitions





05-5488-AH-AH (Mains dimming)*  2700K
 05-5488-BW-BW (Mains dimming)*  2700K
 05-5499-BW-BW (Mains dimming)*  3000K

LED CREE 17,6W |
 A++ A
 2113 lm





Finishing | Acabados | Finitions

 **AH** Ecobright aluminium | Aluminio ecobright | Aluminium Ecobright

 **BW** Matt white | Blanco mate | Blanc mate

Materials | Materiales | Matériaux

 **AL** Aluminium | Aluminio | Aluminium

 **PMMA** Diffuser material PMMA | Material difusor PMMA | Matériau diffusant PMMA

*Mains dimmer compatibility at www.leds-c4.com (Products & Downloads)

*Compatibilidad con reguladores corte de fase en www.leds-c4.com (Productos & Descargas)

*Compatible avec des variateurs en coupure de phase que vous pouvez consulter www.leds-c4.com (Produits & Téléchargements)

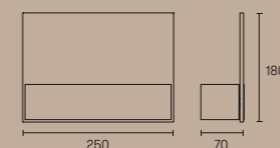
Flat



Minimalist. This wall light is ideal for any space, thanks to its minimalist, simple lines and top-quality materials such as metal and optical glass. Its indirect and diffused light and minimal projection from the wall make this piece easy on the eye.

Minimalista. Este aplique de pared es ideal para instalar en cualquier espacio gracias a sus líneas básicas minimalistas y a la nobleza de sus materiales, como el metal y el vidrio óptico. Su luz indirecta y difusa y la mínima salida desde la pared, dotan a esta luminaria de confort visual.

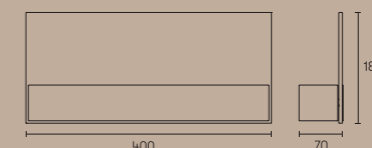
Minimaliste. Cette applique murale est idéale installée dans n'importe quel espace grâce à sa ligne minimaliste et à la noblesse de ses matériaux, tels que le métal et le verre optique. Sa lumière indirecte et diffuse, alliée à sa discrétion sur le mur, dotent cette applique de confort visuel.



Finishing | Acabados | Finitions



05-5093-81-B9 
05-5093-BW-B9 

LED CREE 8W |
A++ A
648 lm 3000K





05-5092-81-B9 
05-5092-BW-B9 

LED CREE 16W |
A++ A
1296 lm 3000K




Finishing | Acabados | Finitions

 **81** Satin nickel | Níquel satinado | Nickel satiné

 **BW** Matt white | Blanco mate | Blanc mate

Materials | Materiales | Matériaux

 **ST** Steel | Acero | Acier

 **GLASS OPT** Diffuser material optic glass | Material difusor cristal óptico | Matériau diffusant verre optique

Jordi Patsí

Flat

Table
Sobremesa
Table

Invisible	192
Flavia	196
Premium	200
Hall	204
Medusa	208
Talk	210
Emy	212



Francesc Vilaró

Invisible



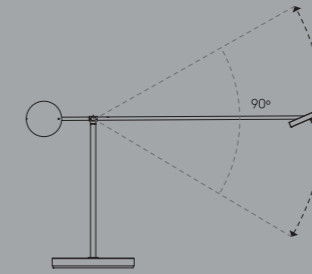
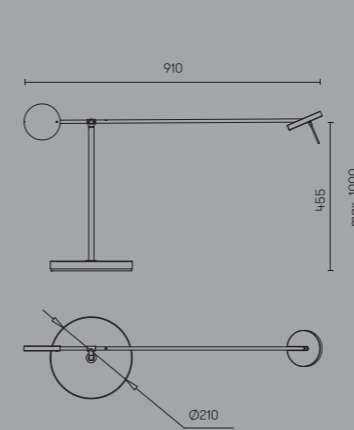


Invisible

Authenticity. Invisible is intuition, functionality and lightness but, above all, simplicity. And this characteristic is the source of its beauty. Its simplicity gives it an intrinsic iconic quality.

Autenticidad. Invisible es intuición, funcionalidad y ligereza, pero sobre todo simplicidad. Y es en esta característica donde radica su belleza. Su simplicidad la convierte en un elemento icónico por sí mismo.

Authenticité. Invisible est intuition, fonctionnalité et légèreté, mais surtout simplicité. Et c'est dans cette caractéristique que se trouve sa beauté. Sa simplicité en fait un élément emblématique par lui-même.



Finishing | Acabados | Finitions

05 Black | Negro | Noir

Materials | Materiales | Matériaux

ST Steel | Acero | Acier

PMMA Diffuser material PMMA | Material difusor
DIF PMMA | Matériau diffusant PMMA

10-5693-05-05 [Touch dimming] ■

LED 9W 765lm 3000K

Collection

Illuminates your spaces alongside the other pieces that comprise this collection.

Colección

Ilumina tus espacios con el resto de piezas que componen esta colección.

Collection

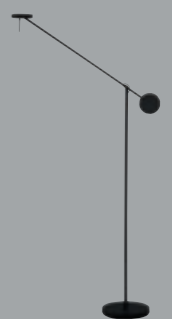
Éclairiez vos espaces avec le reste des pièces de cette collection.



Pendant
Suspensión
Suspension p. 48



Wall
Pared
Mural p. 140



Floor
Pie
Pied p. 216



Benedito Design

Flavia



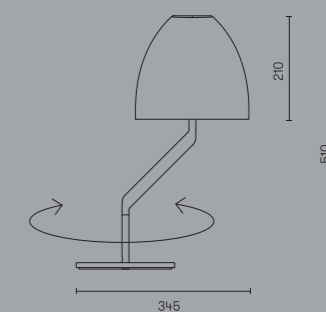
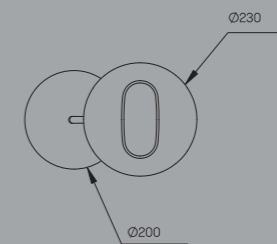
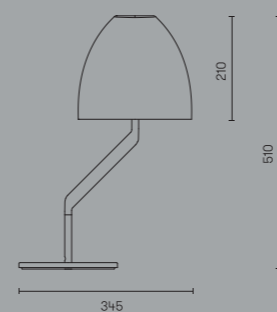


Flavia

Distinction. This collection was designed to stand out in the luminaire market for hotels and residential blocks. Its dynamic and singular solution is expressed through the inclination of the rotating arm and the moulded lampshade.

Distinción. El diseño de esta colección responde a la necesidad de destacar en el mercado de las luminarias para hoteles y complejos residenciales. Su solución dinámica.

Distinction. Le design de cette collection répond à la nécessité de se démarquer sur le marché des luminaires pour les hôtels et complexes résidentiels. Sa solution unique et dynamique s'exprime dans l'inclinaison du bras pivotant et par l'écran moulé.



10-3686-21-M1 ■

1×E-27 Max. 18W |
Max. L=125mm Ø=78mm
A++ C
Fluorescent - LED



Finishing | Acabados | Finitions

■ 21 Chrome | Cromo | Chrome

Materials | Materiales | Matériaux

■ ST Steel | Acero | Acier

■ PMMA Shade material PMMA | Material pantalla
■ SHADE PMMA | Matériels abat-jour PMMA

Collection

Illuminates your spaces alongside the other pieces that comprise this collection.

Colección

Ilumina tus espacios con el resto de piezas que componen esta colección.

Collection

Éclairiez vos espaces avec le reste des pièces de cette collection.



Wall
Pared
Mural p. 144



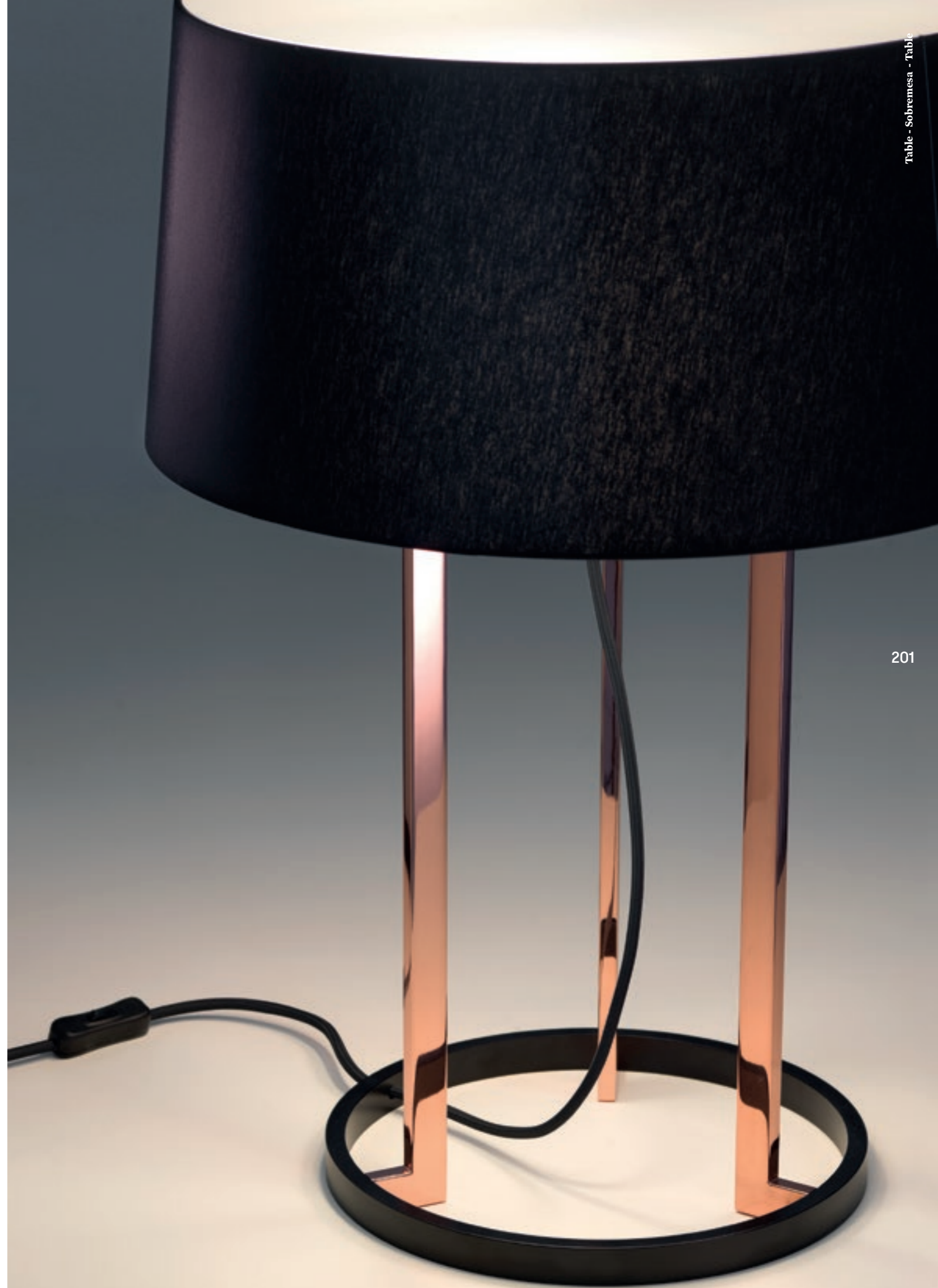
Floor
Pie
Pied p. 220



200

Jordi Llopis

Premium



201

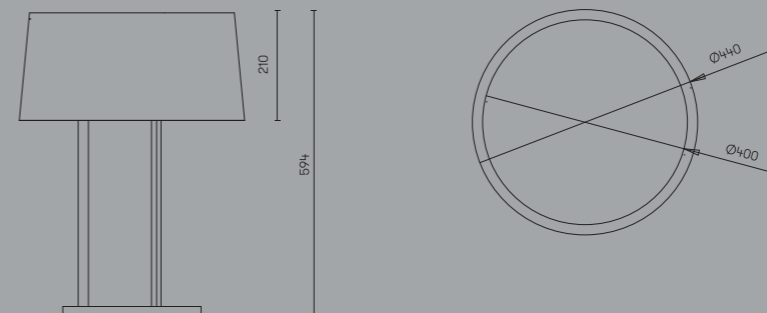


Premium

Warmth. A table lamp boasting a classic yet contemporary design with a copper base and black shade. Its presence, either switched on or off, makes it the ideal luminaire for bedrooms and common areas in hotels.

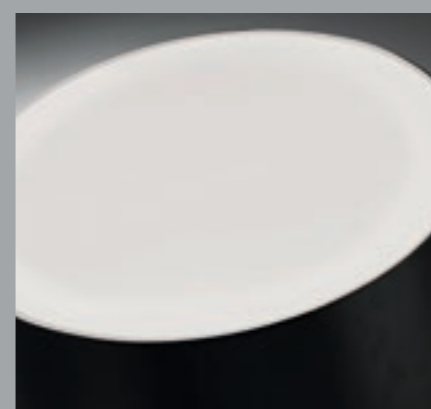
Calidez. Pieza de sobremesa de diseño clásico y contemporáneo con pie de acabados en color cobre y pantalla negra. Su presencia, tanto apagada como encendida, la sitúa como una luminaria ideal para habitaciones y zonas comunes de hoteles.

Chaleureux. Affichant une ligne classique et contemporaine, ce modèle de bureau est muni d'un pied à la finition de couleur cuivre et d'un abat-jour noir. Doté d'une forte présence éteint ou allumé, ce luminaire est idéal dans les chambres et espaces publics des hôtels.



10-5076-06-H13W

3 x E-27 Max. 18W |
Max. L=140mm Ø=52mm
A++ C
Fluorescent - LED



Top diffuser | Difusor Superior | Diffuseur Supérieur



Finishing | Acabados | Finitions

06 Cooper | H13W Black |
Cobre | Cuivre + SHADE Negro | Noir

Materials | Materiales | Matériaux

ST Steel | Acero | Acier

TEXTIL SHADE Shade material fabric | Material pantalla tela | Matériels abat-jour tissu

PMMA DIF Diffuser material PMMA | Material difusor PMMA | Matériau diffusant PMMA

Collection

Illuminates your spaces alongside the other pieces that comprise this collection.

Colección

Ilumina tus espacios con el resto de piezas que componen esta colección.

Collection

Éclairer vos espaces avec le reste des pièces de cette collection.



Floor
Pie
Pied p. 224



204

Nahtang Disseny

Hall



205



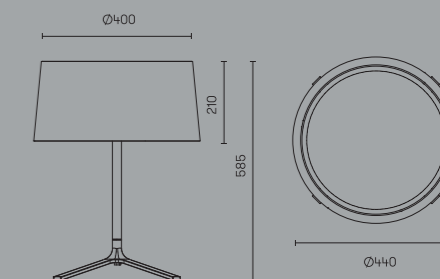
Hall

Simplicity. The main attraction of this collection is the identity conveyed by its contemporary lines without losing the simplicity and neutrality that allows it to coexist in spaces with different styles.

Simplicidad. El principal atractivo de esta colección es la identidad que transmite su línea contemporánea sin perder la simplicidad y la neutralidad que le permite convivir en espacios de diferentes estilos.

Simplicité. Le principal atout de cette collection est l'identité que transmet sa ligne contemporaine sans perdre la simplicité et la neutralité qui lui permettent de s'intégrer dans des espaces de styles différents.

Finishing | Acabados | Finitions



10-1940-05-H13W ■
10-1940-BW-T007 □
3 × E-27 Max. 18W |
Max. L=146mm Ø=52mm
A++ C
Fluorescent - LED



Top diffuser | Difusor Superior | Diffuseur Supérieur



Finishing | Acabados | Finitions

□ BW Matt white | Blanco mate | Blanc mate + □ T007 White | Blanco | Blanc
SHADE

■ 05 Black | Negro | Noir + ■ H13W Black | Negro | Noir
SHADE

Materials | Materiales | Matériaux

ST Steel | Acero | Acier

TEXTIL SHADE Shade material fabric | Material pantalla tela | Matériels abat-jour tissu

PMMA DIF Diffuser material PMMA | Material difusor PMMA | Matériau diffusant PMMA

207

Collection

Illuminates your spaces alongside the other pieces that comprise this collection.

Colección

Ilumina tus espacios con el resto de piezas que componen esta colección.

Collection

Éclairer vos espaces avec le reste des pièces de cette collection.



Wall
Pared
Mural p. 164

Floor
Pie
Pied p. 228



Ramón Valls

Medusa

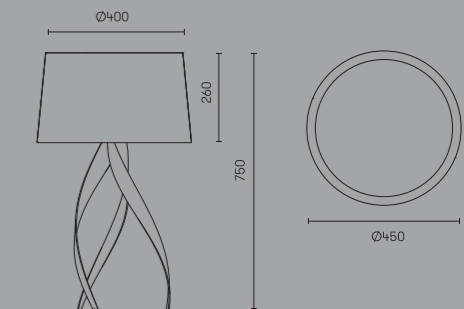
Medusa

Marina. Its white-painted aluminium body and organic forms are reminiscent of a jellyfish, it has great presence in a space and provides good light diffusion.

Marina. Su cuerpo en aluminio pintado de blanco y sus formas orgánicas, recuerdan a una medusa con una gran presencia en el espacio y una buena difusión de la luz.

Air marin. Doté d'un corps en aluminium peint en blanc et de formes organiques, ce luminaire adopte la forme d'une méduse et marque l'espace de sa présence avec une bonne diffusion de la lumière.

Finishing | Acabados | Finitions



10-1824-BW-T002 ■
10-1824-BW-T003 ■

1 x E-27 Max. 18W |
Max. L=140mm
A++ C
Fluorescent - LED



Top diffuser | Difusor Superior | Diffuseur Supérieur



Finishing | Acabados | Finitions

■ BW Matt white | Blanco mate | Blanc mate + ■ SHADE T002 Grey | Gris | Gris

■ BW Matt white | Blanco mate | Blanc mate + ■ SHADE T003 White | Blanco | Blanc

Materials | Materiales | Matériaux

AL Aluminium | Aluminio | Aluminium

PMMA PMMA | PMMA | PMMA

TEXTIL SHADE T002 Shade material fabric | Material pantalla tela | Matériels abat-jour tissu

PVC SHADE T003 Shade material PVC | Material pantalla PVC | Matériels abat-jour PVC

Collection

Illuminates your spaces alongside the other pieces that comprise this collection.

Colección

Ilumina tus espacios con el resto de piezas que componen esta colección.

Collection

Éclairiez vos espaces avec le reste des pièces de cette collection.



Floor
Pie
Pied p. 231



Nahtang Disseny

Talk

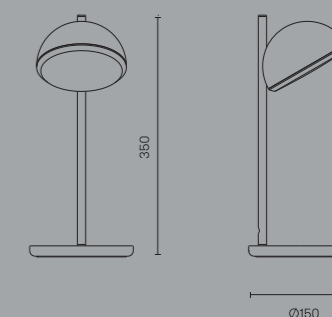
Talk

Vibrancy. Its pieces offer multiple installation options. A single set from this collection enables us to create a highly singular luminaire that can be easily contextualised within intimate and simple spaces. However, when a number are combined, they can grow limitlessly within a space.

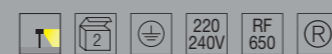
Dinamismo. Sus piezas ofrecen múltiples posibilidades de instalación. Un solo juego de esta colección nos permite tener una luminaria muy singular y fácil de contextualizar en espacios íntimos y sencillos. Pero si se combinan entre ellas, pueden crecer ilimitadamente dentro de un espacio.

Dynamisme. Ses pièces offrent de multiples possibilités d'installation. Un jeu unique de cette collection vous permet d'obtenir un luminaire unique et facile à contextualiser dans des espaces intimes et simples. Mais si elles sont associées entre elles, elles peuvent se développer sans limites dans un espace.

Finishing | Acabados | Finitions



10-5458-Z5-F9
10-5458-BW-F9
LED SAMSUNG 4,5W |
A++ A
290 lm 2700K



Finishing | Acabados | Finitions

Z5 Anthracite grey | Gris antracita | Gris anthracite
BW Matt white | Blanco mate | Blanc mate

Materials | Materiales | Matériaux

AL Aluminium | Aluminio | Aluminium
GLASS Diffuser material glass | Material difusor cristal | Matériau diffusant verre

Collection

Illuminates your spaces alongside the other pieces that comprise this collection.

Colección

Ilumina tus espacios con el resto de piezas que componen esta colección.

Collection

Éclairiez vos espaces avec le reste des pièces de cette collection.



Pendant
Suspensión
Suspension p. 82

Wall
Pared
Mural p. 172



Francesc Vilaró

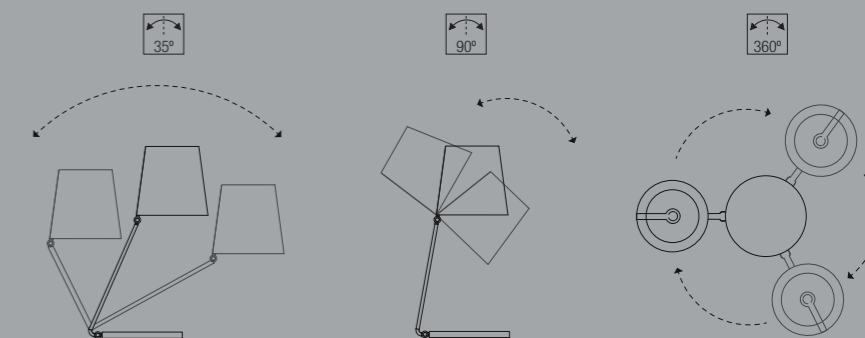
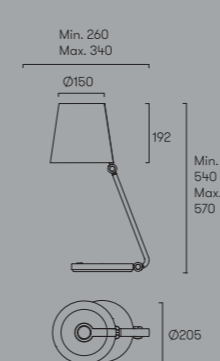
Emy

Emy

Elegance. This table lamp offers mobility that gives it a certain versatility. Its minimalist design and the strength of its materials enable specific atmospheres to be created.

Elegancia. Esta luminaria de sobremesa ofrece una movilidad que la dota de cierta versatilidad. Su diseño de tendencia minimalista y la resistencia de sus materiales permite generar ambientes específicos.

Élégance. Ce luminaire de table fournit une mobilité qui lui donne une certaine polyvalence. Son design minimaliste et la résistance de ses matériaux permettent de créer des ambiances spécifiques.



10-4409-21-12 ■

1 x E-14 Max. 15W |
Max. L=100mm Ø=45mm
A++ C
Fluorescent - LED



Finishing | Acabados | Finitions

SHADE 12 Smoked acrylic shade | Pantalla acrílico fumé | Abat-jour acrylique fumé

21 Chrome | Cromo | Chrome

Materials | Materiales | Matériaux

AL Aluminium | Aluminio | Aluminium

PMMA Diffuser material PMMA | Material difusor PMMA | Matériau diffusant PMMA

PC Shade material polycarbonate | Material pantalla polycarbonato | Matériels abat-jour polycarbonate

Collection

Illuminates your spaces alongside the other pieces that comprise this collection.

Colección

Ilumina tus espacios con el resto de piezas que componen esta colección.

Collection

Éclairer vos espaces avec le reste des pièces de cette collection.



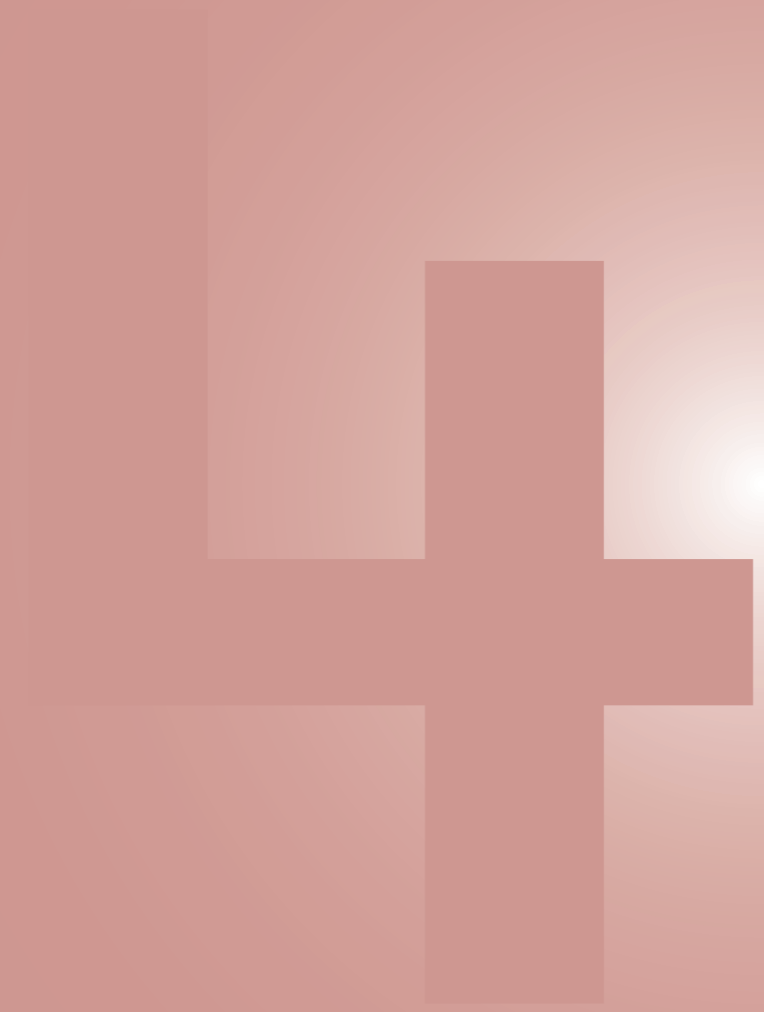
Pendant
Suspensión
Suspension p. 95



Wall
Pared
Mural p. 175



Floor
Pie
Pied p. 234



<u>Floor</u>	Invisible	216
<u>Pie</u>	Flavia	220
	Premium	224
	Hall	228
	Medusa	231
	Emy	234
	Bamboo	237
	Leila	240
	Circ	242
<u>Pied</u>	Bosquet	245
	Hoop	248



Francesc Vilaró

Invisible

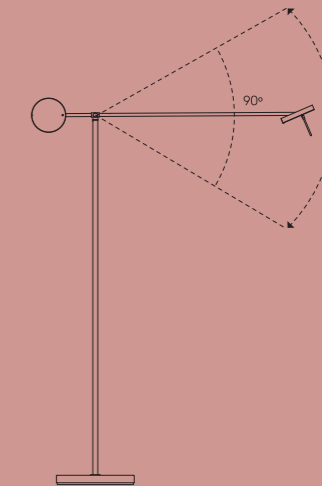
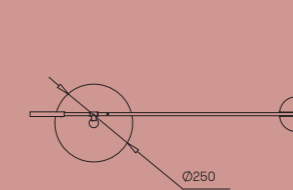
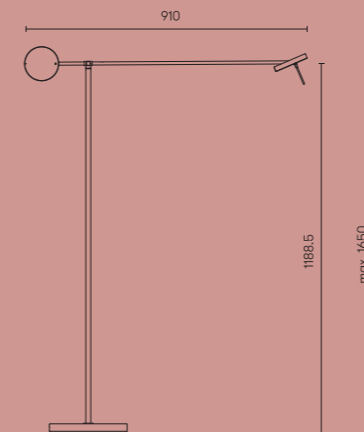


Invisible

Authenticity. Its minimalist design is also reflected in its component parts: which are stripped down to the basics necessary to allow it to perform its function. This lamp has three essential components: an LED light source, two identical circumferences that act as counterweights for one another and a thin tube connecting them.

Autenticidad. Su diseño minimalista también se refleja en los elementos que la componen: los justos y necesarios para cumplir su funcionalidad. Tres son sus componentes esenciales: fuente de luz led, dos circunferencias homólogas que trabajan como contrapeso entre sí y un tubo delgado que los une.

Authenticité. Son design minimaliste se reflète aussi dans les éléments qui la composent : justes et nécessaires pour remplir leur fonction. Trois composants sont essentiels : source de lumière LED, deux circonférences semblables travaillant comme un contrepoids entre elles, et un mince tube qui les relie.



25-5693-05-05 ■

LED 9W 765lm 3000K



Finishing | Acabados | Finitions

■ 05 Black | Negro | Noir

Materials | Materiales | Matériaux

ST Steel | Acero | Acier

PMMA Diffuser material PMMA | Material difusor
PMMA | Matériau diffusant PMMA

Collection

Illuminates your spaces alongside the other pieces that comprise this collection.

Colección

Ilumina tus espacios con el resto de piezas que componen esta colección.

Collection

Éclairer vos espaces avec le reste des pièces de cette collection.



Pendant
Suspensión
Suspension p. 48



Wall
Pared
Mural p. 140



Table
Sobremesa
Table p. 192



220

Benedito Design

Flavia



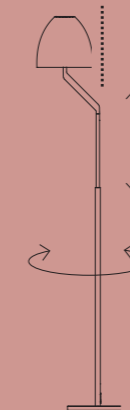
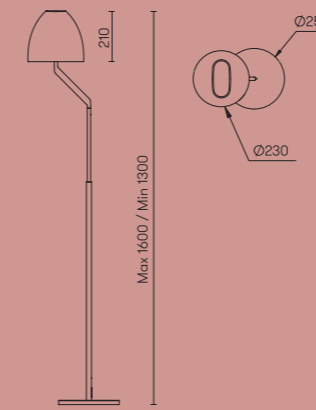
221

Flavia

Distinction. With minimal impact, this piece adds character and provides expressiveness wherever it is installed. Furthermore, great efforts have been made to ensure design consistency between all the pieces to help unify the range.

Distinción. Se trata de una pieza que imprime carácter y que aporta expresividad, mediante una mínima intervención, en los espacios donde se coloca. Además, se ha cuidado la coherencia en el diseño de todas las piezas que ayuda a unificar toda la gama.

Distinction. Il s'agit d'une pièce qui donne du caractère et apporte de l'expressivité grâce à une intervention minimale dans les espaces où elle est placée. En outre, la cohérence a été soignée dans la conception de toutes les pièces aidant ainsi à unifier toute la gamme.



25-3686-21-M1 ■

1×E-27 Max. 18W |
Max. L=125mm Ø=78mm
A++ C
Fluorescent - LED



Finishing | Acabados | Finitions

■ 21 Chrome | Cromo | Chrome

Materials | Materiales | Matériaux

AL Aluminium | Aluminio | Aluminium

ST Steel | Acero | Acier

PMMA Diffuser material PMMA | Material difusor
PMMA | Matériau diffusant PMMA

Collection

Illuminates your spaces alongside the other pieces that comprise this collection.

Colección

Ilumina tus espacios con el resto de piezas que componen esta colección.

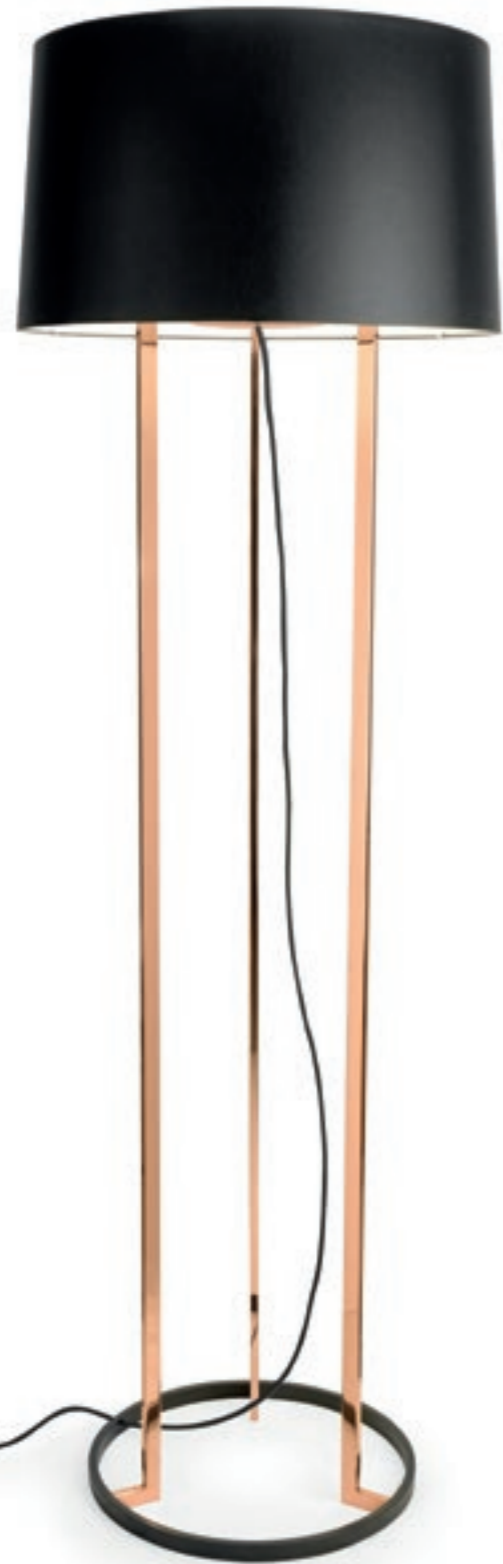
Collection

Éclairer vos espaces avec le reste des pièces de cette collection.



Wall
Pared
Mural p. 144

Table
Sobremesa
Table p. 196



224

225

Jordi Llopis

Premium

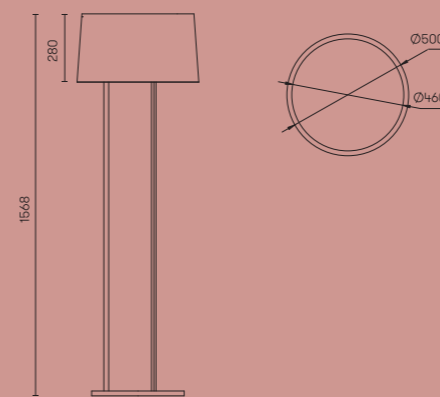


Premium

Warmth. This luminaire with copper features and a black shade has a strong presence. When switched off, it acts as a sculpture to help build the space while, when switched on, it provides a warm and elegant source of light.

Calidez. Esta luminaria de acabados cobre y pantalla negra tiene mucha presencia. Apagada actúa como una escultura que ayuda a construir el espacio y, encendida proporciona una luz cálida y elegante.

Chaleureux. Arborant des finitions cuivre et un abat-jour noir, ce luminaire ne manque pas de présence. Éteint, il agit comme une sculpture qui aide à délimiter l'espace. Allumé, il diffuse une lumière chaleureuse et élégante.



25-5076-06-H13W

3 x E-27 Max. 30W |
Max. L=176mm Ø=60mm
A++ C
Fluorescent - LED



Top diffuser | Difusor Superior | Diffuseur Supérieur



Finishing | Acabados | Finitions

06 Cooper | Cobre | Cuivre + H13W Black | Negro | Noir
SHADE

Materialien | Materiali | Материалы

ST Steel | Acero | Acier

TEXTIL Shade material fabric | Material pantalla tela |
SHADE Matériels abat-jour tissu

PMMA Diffuser material PMMA | Material difusor
DIF PMMA | Matériau diffusant PMMA

Collection

Illuminates your spaces alongside the other pieces that comprise this collection.

Colección

Ilumina tus espacios con el resto de piezas que componen esta colección.

Collection

Éclairiez vos espaces avec le reste des pièces de cette collection.



Table
Sobremesa
Table p. 200



Nahtang Disseny

Hall



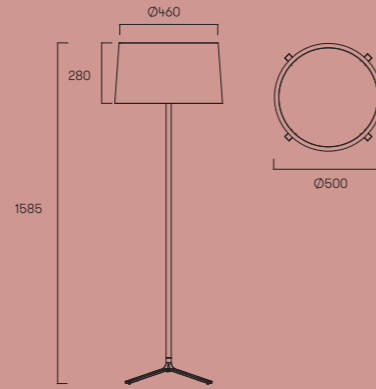
Hall

Simplicity. This collection has been created to make it an essential element of the hotel sector that also enhances the design of its surroundings thanks to the definition of its lines and its more detailed shapes.

Simplicidad. Esta colección se ha creado para posicionarse como una pieza básica en el sector hotelero pero que ofrece un plus en el diseño gracias a la definición de sus líneas y de sus formas más detalladas.

Simplicité. Cette collection a été créée pour se positionner comme une pièce basique dans le secteur hôtelier, mais offre un plus dans son design grâce à la définition de ses lignes et de ses formes plus détaillées.

Finishing | Acabados | Finitions



25-1940-05-H13W ■
25-1940-BW-T007 □

3 x E-27 Max. 30W |
Max. L=176mm Ø=60mm
A++ C
Fluorescent - LED



Finishing | Acabados | Finitions

05 Black | Negro | Noir + SHADE H13W Black | Negro | Noir

BW Matt white | Blanco mate | Blanc mate + SHADE T007 White | Blanco | Blanc

Materials | Materiales | Matériaux

ST Steel | Acero | Acier

TEXTIL SHADE Shade material fabric | Material pantalla tela | Matériels abat-jour tissu

PMMA DIF Diffuser material PMMA | Material difusor PMMA | Matériau diffusant PMMA



Top diffuser | Difusor Superior | Diffuseur Supérieur

Collection

Illuminates your spaces alongside the other pieces that comprise this collection.

Colección

Ilumina tus espacios con el resto de piezas que componen esta colección.

Collection

Éclairer vos espaces avec le reste des pièces de cette collection.



Wall
Pared
Mural p. 164

Table
Sobremesa
Table p. 204



Ramón Valls

Medusa



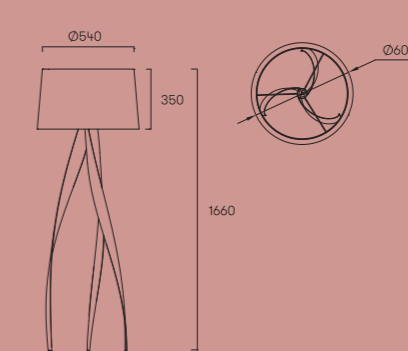
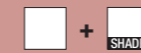
Medusa



Marina. Its organic design provides good light diffusion. The lampshade of this jellyfish-shaped floor lamp comes in two different finishes and materials: grey textile or white PVC.

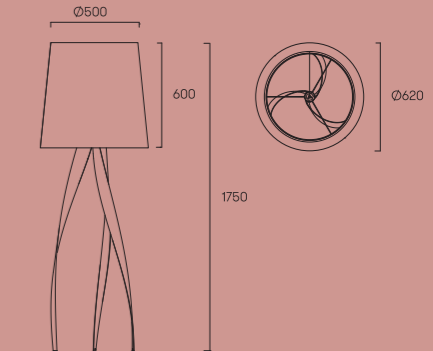
Marina. El diseño orgánico de sus formas permite una buena difusión de la luz. La pantalla de esta luminaria en forma de medusa, ofrece dos acabados y materiales a escoger: textil gris y PVC blanco.



Air marin. La ligne organique de ses formes permet une bonne diffusion de la lumière. L'abat-jour de ce luminaire en forme de méduse offre le choix entre deux finitions et matériaux : textile gris et PVC blanc.

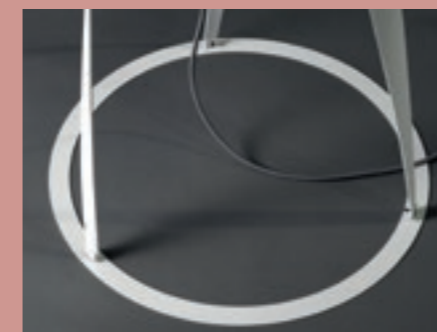
Finishing | Acabados | Finitions




25-1823-BW-T002 
25-1823-BW-T003 
1 x E-27 Max. 30W |
Max. L=195mm Ø=60mm
A++ C
Fluorescent - LED



25-1824-BW-T002 
25-1824-BW-T003 
1 x E-27 Max. 30W |
Max. L=195mm Ø=60mm
A++ C
Fluorescent - LED






71-1759-BW-BW 

Optional accessory | Accesorio opcional |
Accessoire en option




Finishing | Acabados | Finitions

 BW Matt white |
Blanco mate |  T002 Grey |
Blanco mate +  SHADE Gris | Gris

 BW Matt white |
Blanco mate |  T003 White |
Blanco mate +  SHADE Blanco | Blanc

Materials | Materiales | Matériaux

 AL Aluminium | Aluminio | Aluminium

 TEXTIL SHADE T002 Shade material fabric | Material pantalla tela |
Matériels abat-jour tissu

 PVC SHADE T003 Shade material PVC | Material pantalla PVC |
Matériels abat-jour PVC

Collection

Illuminates your spaces alongside the other pieces that comprise this collection.

Colección

Ilumina tus espacios con el resto de piezas que componen esta colección.

Collection

Éclairer vos espaces avec le reste des pièces de cette collection.



Table
Sobremesa
Table p. 208



Francesc Vilaró

Emy

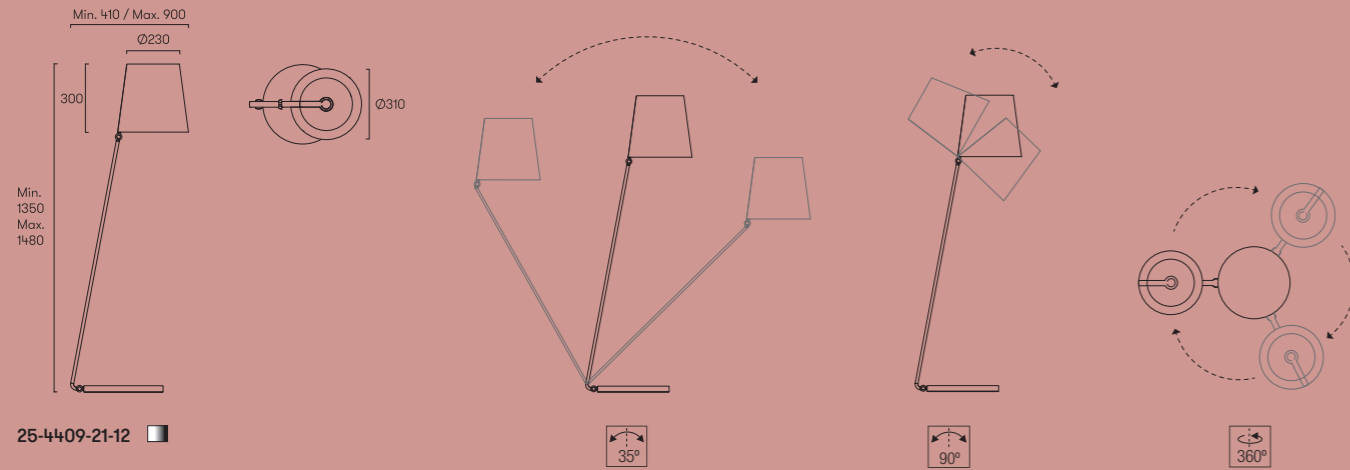


Emy

Elegance. This piece's elegant and classic shapes, offer excellent functionality and highly specific treatment of the light through the carefully designed dual polycarbonate lampshade. Its composition and materials give it a certain presence and a perception of quality.

Elegancia. Esta pieza, de formas elegantes y clásicas, ofrece altas funcionalidades y un trato de la luz muy específico por la estudiada trama de la doble pantalla de policarbonato. Su composición y materiales la dota de cierta presencia y de una percepción de calidad.

Élégance. Cette pièce, aux formes élégantes et classiques, offre de grandes fonctionnalités et un traitement très spécifique de la lumière grâce à la trame étudiée du double écran en polycarbonate. Sa composition et ses matériaux lui donnent une certaine présence et une perception de qualité.



25-4409-21-12

1 x E-27 Max. 30W |
Max. L=180mm Ø=60mm
A++ C
Fluorescent - LED



Finishing | Acabados | Finitions

21 Chrome | Cromo | Chrome

12 Smoked acrylic shade | Pantalla acrílico fumé | Abat-jour acrylique fumé

Materials | Materiales | Matériaux

AL Aluminium | Aluminio | Aluminium

PC Shade material polycarbonate | Material pantalla policarbonato | Matériels abat-jour polycarbonate

PMMA Diffuser material PMMA | Material difusor PMMA | Matériau diffusant PMMA

Collection

Illuminates your spaces alongside the other pieces that comprise this collection.

Colección

Ilumina tus espacios con el resto de piezas que componen esta colección.

Collection

Éclairer vos espaces avec le reste des pièces de cette collection.



Pendant
Suspensión
Suspension p. 95



Wall
Pared
Mural p. 175



Table
Sobremesa
Table p. 212



Gemma Bernal

Bamboo

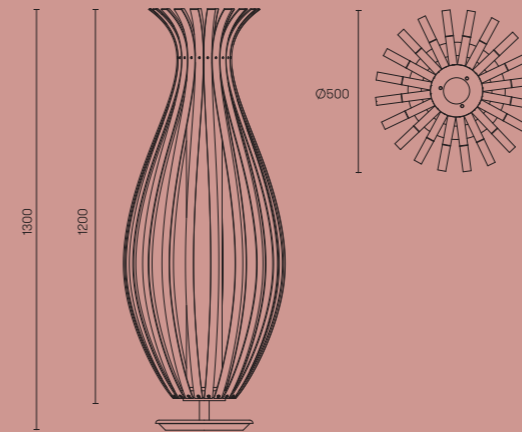


Bamboo

Honesty. Nature and traditional crafts combine in these pieces. The lighting effect created can be adapted to all requirements: abundant light, light effects or shadows and low light. The LED strips are covered by a plastic tube to provide controlled, uniform and diffuse light.

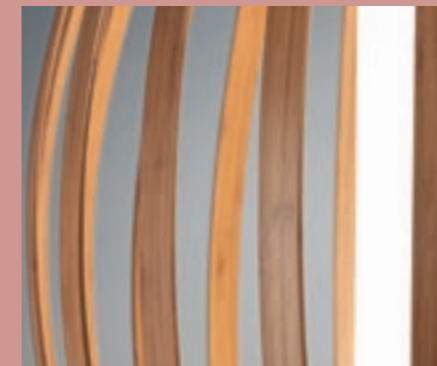
Honestidad. La naturaleza y la artesanía se unen en estas piezas. El efecto lumínico que genera se adapta a todas las necesidades: mucha luz, efectos de luz y sombras y poca luz. Las tiras de led recubiertas con un tubo de plástico nos dan una luz controlada, uniforme y difusa.

Honnêteté. La nature et l'artisanat sont réunis dans ces pièces. L'effet d'éclairage qu'il génère s'adapte à tous les besoins : beaucoup de lumière, des jeux de lumière et d'ombres et peu de lumière. Les bandes de LED recouvertes d'un tube en plastique vous donnent une lumière uniforme, diffuse et contrôlée.



25-4035-CT-93 ■

LED 22W A++ A
1870 lm 3000K



Bamboo | Bambú | Bambou



Finishing | Acabados | Finitions

CT Wood brown | Marrón madera | Bois marron

Materials | Materiales | Matériaux

ST Steel | Acero | Acier

WOOD Wood | Marrón | Bois

PMMA Diffuser material PMMA | Material difusor PMMA | Matériau diffusant PMMA

Collection

Illuminates your spaces alongside the other pieces that comprise this collection.

Colección

Ilumina tus espacios con el resto de piezas que componen esta colección.

Collection

Éclairiez vos espaces avec le reste des pièces de cette collection.



Pendant
Suspensión
Suspension p. 89



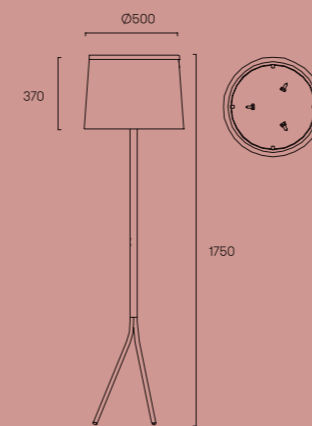
Benedito Design

Leila

Neutrality. This elegant lamp provides direct and indirect light, fitting perfectly into any space. Its design combines a white cloth shade with an aluminium structure and chrome features.

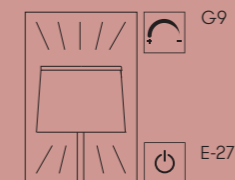
Neutralidad. Es una elegante lámpara que ofrece una luz directa e indirecta integrándose fácilmente en el espacio. Su diseño combina una pantalla en tela blanca con una estructura de aluminio con detalles cromados.

Neutralité. C'est un lampadaire élégant qui diffuse une lumière directe et indirecte en s'intégrant facilement dans l'espace. Son design conjugue un abat-jour en toile blanche avec une structure en aluminium ponctuée de détails chromés.



25-2407-AG-14

3 x E-27 Max. 23W |
Max. L=140 Ø=60mm
+ 3 x G9 Max. 40W
A++ C OSRAM included



Finishing | Acabados | Finitions

SHADE 14 White | Blanco | Blanc

AG Aluminium with chrome | Aluminio con cromo | Aluminium avec chrome

Materials | Materiales | Matériaux

AL Aluminium | Aluminio | Aluminium

TEXTIL Shade material fabric | Material pantalla tela |
SHADE Matériels abat-jour tissu

Collection

Illuminates your spaces alongside the other pieces that comprise this collection.

Colección

Ilumina tus espacios con el resto de piezas que componen esta colección.

Collection

Éclairer vos espaces avec le reste des pièces de cette collection.



Pendant
Suspensión
Suspension p. 128



Josep Patsí

Circ

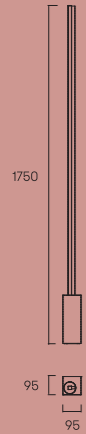


Circ

Lightness. This luminaire offers minimalist expression with minimal volume, but it is capable of filling any space due to its highly effective light diffusion. It gives a sensation of lightness and it appears as though the piece is emitting its own light.

Ligereza. Es la mínima expresión con un mínimo volumen, pero con la capacidad de llenar cualquier espacio por la difusión de su iluminación. Aporta una sensación de ligereza y de que la pieza tiene una iluminación propia.

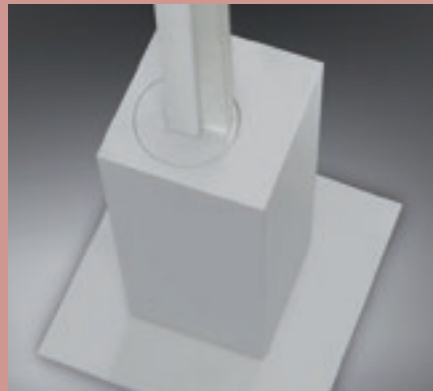
Légèreté. Réduit à sa plus simple expression dans un minimum de volume, ce modèle sait néanmoins remplir n'importe quel espace par la diffusion de sa lumière. Il apporte une sensation de légèreté et de lumière qui émane de nulle part.



25-2934-BW-M3

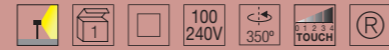
LED 27W A++ A
2.592 lm 3000K

244



71-2934-BW-BW

Accessory for transit areas
Accesorio para zonas transitadas
Accessoire pour zones de passage



Finishing | Acabados | Finitions

BW Matt white | Blanco mate | Blanc mate

Materials | Materiales | Matériaux

AL Aluminium | Aluminio | Aluminium

PMMA Diffuser material PMMA | Material difusor PMMA | Matériau diffusant PMMA

Collection

Illuminates your spaces alongside the other pieces that comprise this collection.

Colección

Ilumina tus espacios con el resto de piezas que componen esta colección.

Collection

Éclairer vos espaces avec le reste des pièces de cette collection.



Pendant
Suspensión
Suspension p. 56



Ceiling
Techo
Plafond p. 260



Ramón Valls

Bosquet

245

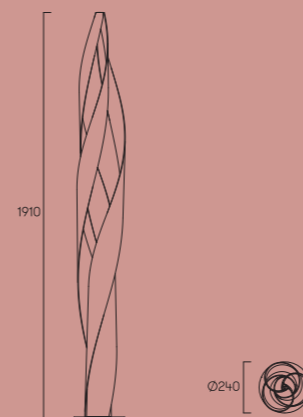


Bosquet

Contrast. Like a sculpture, this aluminium piece with organic forms creates light, shadow and reflections in the form of a spiral reaching towards the ceiling, giving it volume.

Contraste. Como si se tratase de una escultura, esta pieza de aluminio y de formas orgánicas, genera luces y sombras y reflejos en forma de espiral hacia el techo que le da volumen.

Contraste. Telle une sculpture, cette pièce en aluminium aux formes organiques produit des jeux d'ombres et de lumière ponctués de reflets en forme de spirale ascendante qui lui donnent du volume.



25-1837-05-05 ■

1 x E-27 Max. 150W |
 Max. L=195 mm Ø=60 mm
 A++ C - Halogen - Fluorescent - LED
 Recommended E-27 PAR 30 Max. 75W



Finishing | Acabados | Finitions

■ 05 Black | Negro | Noir

Materials | Materiales | Matériaux

AL Aluminium | Aluminio | Aluminium



Josep Patsí

Hoop

Hoop

Adjustable. The arm of this lamp describes a large circle and its size makes it a decorative element that fills a space. The arm can be extended and the height adjusted, and it can also be rotated 360° from the base.

Regulable. El brazo de esta luminaria de pie describe un gran círculo y sus dimensiones la convierten en un elemento decorativo que llena el espacio. Su brazo es extensible y regulable en altura y tiene la capacidad de girar 360° desde la base.

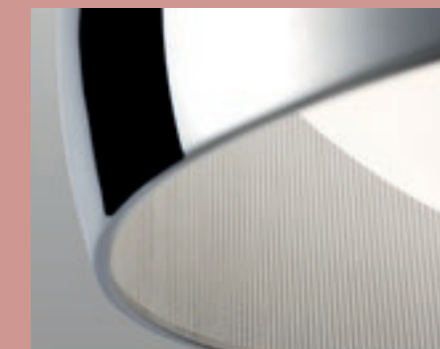
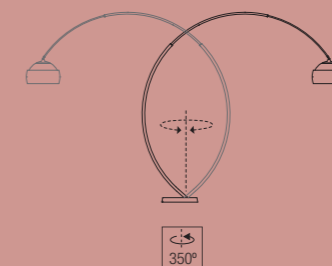
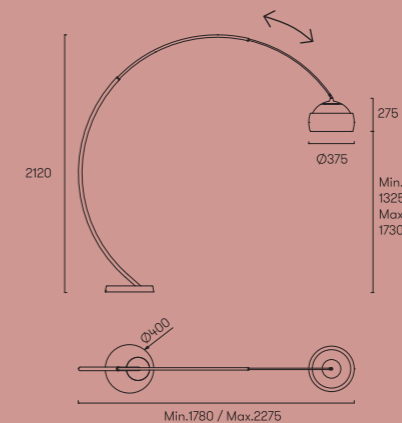
Réglable. Le bras en demi-arc et les dimensions de ce lampadaire lui confèrent une présence décorative qui remplit l'espace. Extensible et réglable en hauteur, le bras peut tourner sur 360° depuis le socle.

Finishing | Acabados | Finitions



25-0058-BW-M1

1 x E-27 Max. 23W |
Max. L=160 mm Ø=60 mm
A++ C - Fluorescent - LED



Finishing | Acabados | Finitions

BW Matt white | Blanco mate | Blanc mate
 21 Chrome | Cromo | Chrome

Materials | Materiales | Matériaux

ST Steel | Acero | Acier

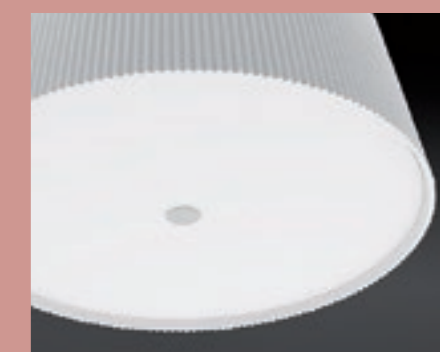
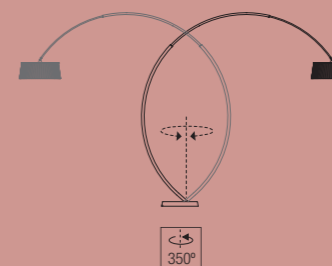
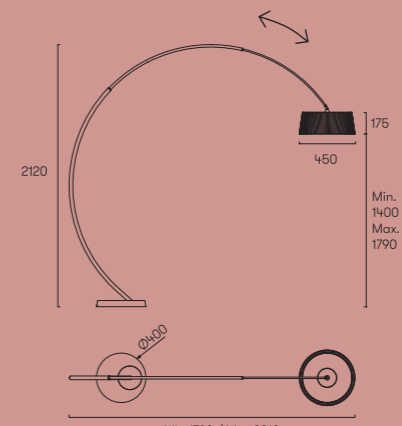
PMMA Diffuser material PMMA | Material difusor PMMA
DIF PMMA | Matériau diffusant PMMA

249



25-0057-BW-M1

3 x E-27 Max. 23W |
Max. L=140 mm Ø=60 mm
A++ c - Fluorescent - LED



Finishing | Acabados | Finitions

BW Matt white | Blanco mate | Blanc mate

Materials | Materiales | Matériaux

ST Steel | Acero | Acier

PMMA Diffuser material PMMA | Material difusor PMMA
DIF PMMA | Matériau diffusant PMMA

PUR Shade material polyurethane | Material pantalla poliuretano
SHADE | Matériels abat-jour polyuréthane



<u>Ceiling</u>	Six	252
<u>Techo</u>	Igloo	255
<u>Plafond</u>	Spin	258
	Circ	260
	Net	262
	Ocho	264
	Tandem	266
	Single	268
	Ibis	270



Josep Patsí

Six

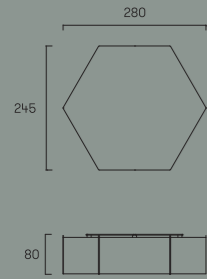


Six

Spectacular. Offers a high light output thanks to the PCB LED backlight and it is very easy to install. Its hexagonal geometric shape and the three different height options allow for the creation of spectacular compositions.

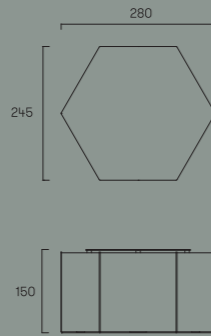
Espectacular. Ofrece un alto rendimiento lumínico gracias al led PCB backlight y es de muy fácil instalación. Su forma geométrica hexagonal y el juego de tres alturas diferentes permite crear composiciones espectaculares.

Spectaculaire. Très facile à installer, ce luminaire offre un rendement lumineux élevé grâce à sa lampe LED à rétroéclairage sur PCB. Sa forme géométrique hexagonale et le jeu de trois hauteurs différentes permet de créer des compositions spectaculaires.



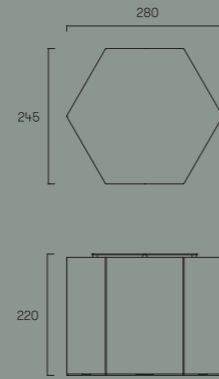
15-1950-BW-M1V1

LED 13W |
1440 lm 3000K



15-1956-BW-M1V1

LED 13 W |
1440 lm 3000K



15-1959-BW-M1V1

LED 13W |
1440 lm 3000K



Finishing | Acabados | Finitions

BW Matt white | Blanco mate | Blanc mate

Materials | Materiales | Matériaux

AL Aluminium | Aluminio | Aluminium

PC Diffuser material polycarbonate | Material difusor policarbonato | Matériau diffusant polycarbonate



Its special design allows for multiple combinations.
Su especial diseño permite múltiples combinaciones.
Son design spécial permet de nombreuses combinaisons.

Connection scheme.
Esquema de conexión.
Schéma de connexion.

For dimmable versions, please get in contact with your sales representative.
Para versiones regulables, por favor consulte con equipo comercial.
Pour les versions réglables, veuillez consulter l'équipe commerciale.



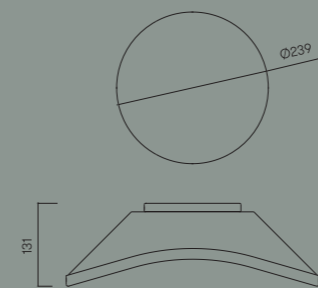


Igloo

Delicacy. This LED ceiling lamp adapts to any space thanks to its organic lines and its direct, sensual and delicate light.

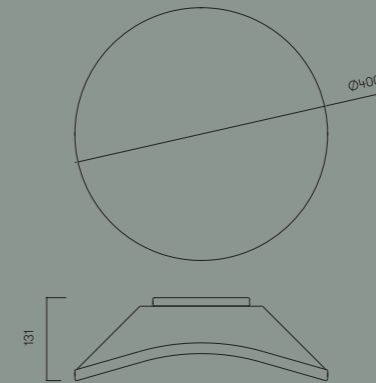
Delicadeza. Esta luminaria led de techo se adapta a cualquier espacio gracias a sus formas orgánicas y a su luz directa, sensual y delicada.

Délicatesse. Ce plafonnier LED s'adapte à n'importe quel espace grâce à ses formes organiques et à sa lumière directe, sensuelle et délicate.



15-5276-BW-M1 (Mains dimming)* ■

LED OSRAM A++ A
1.000 lm 2700K



15-5277-BW-M1 (Mains dimming)* ■

LED OSRAM 32W A++ A
3.200 lm 2700K



Finishing | Acabados | Finitions

■ **BW** Matt white | Blanco mate | Blanc mate

Materials | Materiales | Matériaux

■ **ST** Steel | Acero | Acier

■ **PMMA** Diffuser material PMMA | Material difusor PMMA | Matériau diffusant PMMA

* Mains dimmer compatibility at www.leds.c4.com (Products & Downloads)

* Compatibilidad con reguladores corte de fase en www.leds-c4.com (Productos & Descargas)

* Compatible avec des variateurs en coupure de phase que vous pouvez consulter www.leds-c4.com (Produits & Téléchargements)

Collection

Illuminates your spaces alongside the other pieces that comprise this collection.

Colección

Ilumina tus espacios con el resto de piezas que componen esta colección.

Collection

Éclairer vos espaces avec le reste des pièces de cette collection.



Wall
Pared
Mural p. 178



Nahtrang Disseny

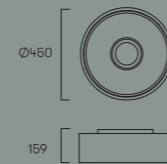
Spin

Spin

Kindness. The basic lighting concept of this luminaire allows it to fit into contract spaces and counteract their cold atmosphere, bringing warmth and kindness. In the home, it also serves as a neutral but decorative piece that illuminates and brings warmth to all environments.

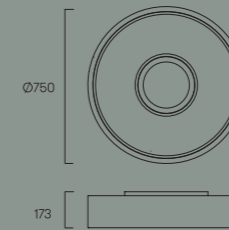
Amabilidad. Su concepción básica de la iluminación le permite integrarse en espacios contract para contrarrestar su ambiente frío y dotarlos de amabilidad. Y también en el hogar presentándose como una pieza neutra pero decorativa que ilumina y da calidez a todos los entornos.

Amabilité. Sa conception basique de l'éclairage lui permet de s'intégrer dans des espaces professionnels pour contrer l'ambiance froide et leur apporter un caractère plus chaleureux. Il peut aussi convenir à un foyer en se présentant comme une pièce neutre mais décorative qui éclaire et apporte de la chaleur à tous les milieux.



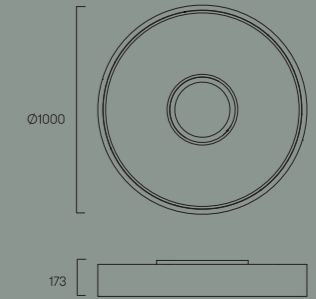
15-4601-21-05 ■
15-4601-21-14 ■

3 × E-27 Max. 23W |
Max. L=190mm Ø=60mm
A++ C
Fluorescent - LED



15-4607-21-05 ■
15-4607-21-14 ■

5 × E-27 Max. 30W |
Max. L=190mm Ø=60mm
A++ C
Fluorescent - LED



15-4615-21-05 ■
15-4615-21-14 ■

7 × E-27 Max. 30W |
Max. L=190mm Ø=60mm
A++ C
Fluorescent - LED



Finishing | Acabados | Finitions

■ **BW** Matt white | Blanco mate | Blanc mate

■ **05** Black | Negro | Noir

■ **21** Chrome | Cromo | Chrome

Materials | Materiales | Matériaux

■ **ST** Steel | Acero | Acier

■ **PMMA** Diffuser material PMMA | Material difusor PMMA

■ **TEX** Fabric | Tela | Tissu

Collection

Illuminates your spaces alongside the other pieces that comprise this collection.

Colección

Ilumina tus espacios con el resto de piezas que componen esta colección.

Collection

Éclairiez vos espaces avec le reste des pièces de cette collection.



Pendant
Suspensión
Suspension p. 122



Josep Patsí

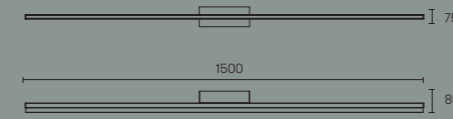
Circ

Circ

Lightness. This piece is suitable for both domestic spaces and large-scale spaces since various combinations of shapes and sizes can be made.

Ligereza. Esta pieza puede adecuarse a diferentes espacios, tanto domésticos como de grandes dimensiones, gracias a la posibilidad de realizar combinaciones de varios tamaños y formas.

Légèreté. Ce modèle peut s'adapter à différents espaces, qu'ils soient domestiques ou grand format, grâce à la possibilité de combiner des dimensions et formes variées.



15-4875-BW-M3 100
240V

15-4871-BW-M3 (Mains dimming)* 220
240V

LED 26W A++ A
2.496 lm 3000K



Finishing | Acabados | Finitions

BW Matt white | Blanco mate | Blanc mate

Materials | Materiales | Matériaux

AL Aluminium | Aluminio | Aluminium

PMMA Diffuser material PMMA | Material difusor PMMA | DIF PMMA | Matériau diffusant PMMA

* Mains dimmer compatibility at www.leds-c4.com (Products & Downloads)

* Compatibilidad con reguladores corte de fase en www.leds-c4.com (Productos & Descargas)

* Compatible avec des variateurs en coupure de phase que vous pouvez consulter www.leds-c4.com (Produits & Téléchargements)

Collection

Illuminates your spaces alongside the other pieces that comprise this collection.

Colección

Ilumina tus espacios con el resto de piezas que componen esta colección.

Collection

Éclairer vos espaces avec le reste des pièces de cette collection.



Pendant
Suspensión
Suspension p. 56



Floor
Pie
Pied p. 242



Josep Patsí

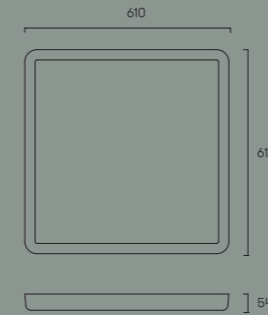
Net

Net

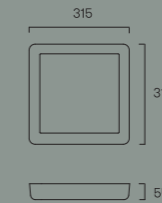
Purity. This luminaire has a functional design that minimises the space, and its perimeter LED emits a uniform light over its entire surface, which allows for different applications and formats within a space.

Pureza. Esta luminaria de diseño funcional minimiza el espacio y, mediante su led perimetral, ofrece una luz uniforme en toda su superficie que permite diferentes aplicaciones y formatos en el espacio.

Pureté. Ce luminaire au design fonctionnel minimise l'espace et, grâce à sa LED de périmètre, il offre une lumière uniforme sur toute sa surface qui lui permet d'adopter différentes applications et formats dans l'espace.



15-0003-BW-M1

LED 55W A++ A
5.280 lm 3000K

15-3536-BW-M1

LED 30W A++ A
2.880 lm 3000K

71-2241-00-00

Controlador con mando a distancia para
Versiónes Standard
Controller with remote control for
Standard Version
Contrôleur avec télécommande pour
Versions standard



Finishing | Acabados | Finitions

BW Matt white | Blanco mate |
Blanc mate

Materials | Materiales | Matériaux

PS Diffuser material polystyrene | Material difusor
poliestireno | Matériau diffusant polystyrène

PUR Polyurethane | Poliuretano | Polyuréthane

Collection

Illuminates your spaces alongside the other pieces that comprise this collection.

Colección

Ilumina tus espacios con el resto de piezas que componen esta colección.

Collection

Éclairer vos espaces avec le reste des pièces de cette collection.



Pendant
Suspensión
Suspension p. 98



Josep Patsí

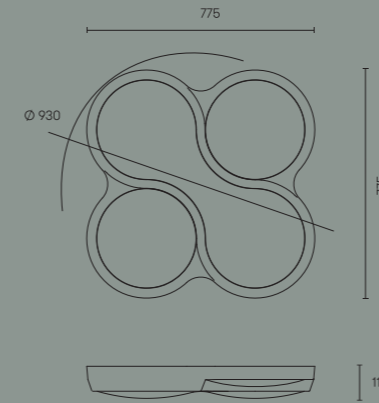
Ocho

Ocho

Sinuous. This large ceiling light with a high light output integrates harmoniously with the ceiling and into any space, owing to its soft and sinuous shapes. Its design is based on the geometry of the figure eight.

Sinuosa. Este plafón de grandes dimensiones y de alto rendimiento lumínico, se integra armónicamente en el techo y en los espacios por sus formas suaves y sinuosas. Su diseño está basado en la geometría del número ocho.

Sinueux. Ce plafonnier de grande dimension à rendement lumineux élevé s'intègre harmonieusement au plafond et dans l'espace grâce à ses formes douces et galbées. Son design épouse la géométrie du chiffre huit.



15-2807-14-M1

4 x 2GX13 55W A++ B

Independent double lighting system
Sistema de doble iluminación independiente
Système double éclairage indépendant



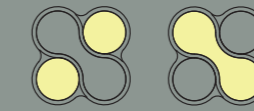
Finishing | Acabados | Finitions

14 White | Blanco | Blanc

Materials | Materiales | Matériaux

PUR Polyurethane | Poliuretano | Polyuréthane

PMMA Diffuser material PMMA | Material difusor
 DIF PMMA | Matériau diffusant PMMA





Benedito Design

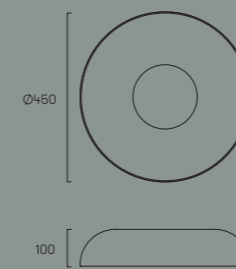
Tandem

Tandem

Rational. With a sombre and rational exterior, this luminaire adapts to a wide range of spaces to offer a technically impeccable interior. This luminaire is the expression of simplicity with a guarantee for the future.

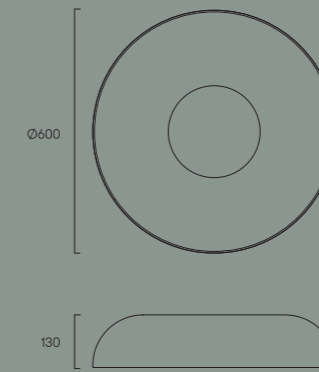
Racional. Con un exterior sobrio y racional se adecua a una amplia gama de interiores y ofrece un interior técnicamente impecable. Esta luminaria es la expresión de la sencillez con garantía de futuro.

Rationnel. Doté d'une ligne extérieure sobre et rationnelle, ce modèle s'adapte à un vaste éventail de décors tout en offrant un intérieur techniquement impeccable. Ce luminaire est synonyme de simplicité et de garantie d'avenir.



15-0078-BW-M1

1 × 2GX13 55W A++ B



15-0056-BW-M1

1 × 2GX13 40W
+ 1 × 2GX13 22 W A++ B

Finishing | Acabados | Finitions

BW Matt white | Blanco mate | Blanc mate

Materials | Materiales | Matériaux

ST Steel | Acero | Acier

PMMA Diffuser material PMMA | Material difusor
DIF PMMA | Matériau diffusant PMMA

Collection

Illuminates your spaces alongside the other pieces that comprise this collection.

Colección

Ilumina tus espacios con el resto de piezas que componen esta colección.

Collection

Éclairiez vos espaces avec le reste des pièces de cette collection.



Pendant
Suspensión
Suspension p. 118



Josep Patsí

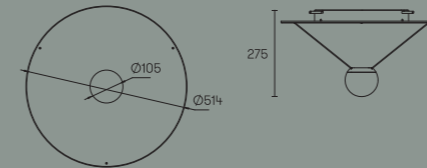
Single

Single

Floating. The indirect light emitted by this luminaire is derived from a floating sphere that directs the light towards a circular reflector, creating a very comfortable atmosphere. It uses a high-performance LED with a simple and minimalistic design.

Flotante. La luz indirecta de esta luminaria se genera gracias a una esfera flotante que dirige la luz hacia un reflector circular y que provoca un ambiente muy confortable. Emplea un led de alto rendimiento con un diseño sencillo y minimalista.

Flottant. La lumière indirecte de ce luminaire est produite par une sphère flottante qui la dirige vers un réflecteur circulaire, pour une atmosphère très confortable. Muni d'une lampe LED haut rendement de ligne simple et minimaliste.



15-5099-D9-D9 100
240V

15-5100-D9-D9 (Mains dimming)* 220
240V

LED 25W
A++ A 3.011 lm 2700K

* Mains dimmer compatibility at www.leds.c4.com
(Products & Downloads)

* Compatibilidad con reguladores corte de fase en
www.leds.c4.com (Productos & Descargas)

* Compatible avec des variateurs en coupure de phase
que vous pouvez consulter www.leds.c4.com
(Produits & Téléchargements)



Finishing | Acabados | Finitions

D9 Silver leaf | 21 Chrome |
Pan de plata | Cromo | Chrome
Feuille d'argent

Materials | Materiales | Matériaux

ST Steel | Acero | Acier

Ibis

Classic. Its timeless design, minimalist forms and indirect light have made this luminaire a popular choice for almost 25 years. A true classic.

Clásica. Su diseño atemporal, sus formas minimalistas y su luz indirecta, han permitido que esta luminaria permanezca en activo durante casi 25 años. Es todo un clásico.

Classique. Son design intemporel, ses lignes minimalistes et sa lumière indirecte ont permis à ce luminaire de rester actif pendant près de 25 ans. Une valeur sûre.

Finishing | Acabados | Finitions



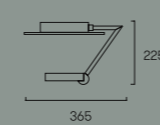
Finishing | Acabados | Finitions

81 Satin nickel | Níquel satinado | Nickel satiné

BW Matt white | Blanco mate | Blanc mate

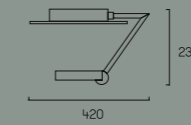
Materials | Materiales | Matériaux

ST Steel | Acero | Acier



IBIS C/27-81

1 × R7s L=78 Max. 150W
A++ C
OSRAM included



IBIS C/37-81
IBIS C/37-BW

1 × R7s L=118 Max. 200W
A++ A
OSRAM included



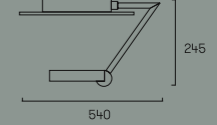
15-3231-BW-BWV1 100
15-3231-81-81V1 240V

15-4785-81-81 (Mains dimming)* 220
15-4785-BW-BW (Mains dimming)* 240V

LED CREE 26W
A++ A 1.944 lm 3000K



DIF



IBIS C/47-81
IBIS C/47-BW

1 × R7s L=118 Max. 300W
A++ C
OSRAM included



Grok Team

Ibis

* Mains dimmer compatibility at www.leds.c4.com
(Products & Downloads)

* Compatibilidad con reguladores corte de fase en
www.leds-c4.com (Productos & Descargas)

* Compatible avec des variateurs en coupure de phase
que vous pouvez consulter www.leds-c4.com
(Produits & Téléchargements)




General information
Información general
Information générale

	Materials	Materiales	Matériaux
ABS	ABS	ABS	ABS
AL	Aluminium	Aluminio	Aluminium
PMMA	PMMA	PMMA	PMMA
PUR	Polyurethane	Poliuretano	Polyuréthane
SIL	Silicone	Silicona	Silicone
ST	Steel	Acero	Acier
TEXTIL	Fabric	Tela	Tissu
WOOD	Wood	Marrón	Bois
ZAMAK	Zamak	Zamak	Zamak

	Diffusers	Difusores	Diffuseurs
ACR DIF	Diffuser material acrylic	Material difusor acrílico	Materiau diffusant acrylique
GLASS DIF	Diffuser material glass	Material difusor cristal	Materiau diffusant verre
GLASS MAT DIF	Diffuser material matt glass	Material difusor vidrio mate	Materiau diffusant verre mat
GLASS OPAL3 DIF	Diffuser material triplex opal glass	Material difusor cristal opal triplex	Materiau diffusant verre opal triplex
GLASS OPT DIF	Diffuser material optic glass	Material difusor cristal óptico	Materiau diffusant verre optique
GLASS TRANS DIF	Diffuser material transparent glass	Material difusor cristal transparente	Materiau diffusant verre transparent
PMMA DIF	Diffuser material PMMA	Material difusor PMMA	Materiau diffusant PMMA
PC DIF	Diffuser material polycarbonate	Material difusor policarbonato	Materiau diffusant polycarbonate
PS DIF	Diffuser material polystyrene	Material difusor poliestireno	Materiau diffusant polystyrène

	Shades	Pantallas	Abat-jours
PMMA SHADE	Shade material PMMA	Material pantalla PMMA	Matériels abat-jour PMMA
PC SHADE	Shade material polycarbonate	Material pantalla policarbonato	Matériels abat-jour polycarbonate
PUR SHADE	Shade material polyurethane	Material pantalla poliuretano	Matériels abat-jour polyuréthane
PVC SHADE	Shade material PVC	Material pantalla PVC	Matériels abat-jour PVC
TEXTIL SHADE	Shade material fabric	Material pantalla tela	Matériels abat-jour tissu

	Finishings	Acabados	Finitions
	03 T002 Grey	Gris	Gris
	05 H13W T005 Black	Negro	Noir
	06 Cooper	Cobre	Cuivre
	12 Smoked	Fumé	Fumé
	14 T003 T007 White	Blanco	Blanc
	21 Chrome	Cromo	Chrome
	23 Golden	Dorado	Doré
	27 Matt satin finished brass	Latón satinado mate	Laiton satiné mat
	78 White lacquered	Lacado blanco	Laqué en blanc
	81 Satin nickel	Níquel satinado	Nickel satiné
	AH Ecobright aluminium	Aluminio ecobright	Aluminium ecobright
	AJ Opera grey	Gris ópera	Gris opéra
	AP Golden pleated interior shade	Pantalla interior plisada dorada	Intérieur d'abat-jour plissé doré
	AQ Metallic grey. Silver pleated interior shade	Gris metalizado. Pantalla interior plisada plata	Gris metalisé. Intérieur d'abat-jour plissé argenté
	AF Satin aluminium	Aluminio satinado	Aluminium satiné
	AG Aluminium with chrome	Aluminio con cromo	Aluminium avec chrome
	BY Beige	Beige	Beige
	BW Matt white	Blanco mate	Blanc mate
	CH Metallic grey	Gris metalizado	Gris metalisé
	CI Brown	Marrón	Marron
	CT Wood brown	Marrón madera	Bois marron
	D9 Silver leaf	Pan de plata	Feuille d'argent
	F5 Painted gold	Oro pintado	Or peint
	N3 Grey texture	Gris textura	Gris à effet de texture
	Z5 Anthracite grey	Gris antracita	Gris anthracite
	White	Blanco	Blanc
	Orange	Naranja	Orange
	Green	Verde	Vert

	Simbols	Simbología	Symboles
	Class I	Clase I	Classe I
	Class II	Clase II	Classe II
	Registered models	Modelos registrados	Modèles enregistrés
	Resistance to incandescent wire at XXX°C	Resistente al hilo incandescente a XXX°C	Tenue au feu XXX°C
	Items per box	Uds. de embalaje	Unité d'emballage
	Ceiling installation	Instalación en el techo	Installation au plafond
	Dimmer	Regulador de intensidad	Régulateur d'intensité
	Touch dimmer	Regulador de intensidad táctil	Variateur d'intensité tactile
	On/off switch	Interruptor de encendido	Interrupteur simple allumage
	Double on/off switch	Doble interruptor de encendido	Interrupteur double allumage
	Cable on/off switch	Interruptor de encendido en el cable	Interrupteur d'allumage sur le câble
	Remote control included	Mando a distancia incluido	Télécommande fournie
	Controller with remote control	Controlador con mando a distancia	Contrôleur avec télécommande
	Batteries included	Pilas incluidas	Piles fournies
	Please, contact our sales team	Consulte con equipo comercial	Consultez l'équipe commerciale
	Electrical compatibility	Compatibilidad eléctrica	Compatibilité électrique
	Corte de empotramiento	Hole dimensions for recessing	Coupe d'encastrement
	Rotating	Giratorio	Giratoire
	355° rotation	Giratorio 355°	Giratoire 355°
	A++ A A++ B A+ A A++ C	Eficiencia energética	Energy efficiency
	Shade material	Material pantalla	Matériel Abat-jour
	Diffuser material	Material difusor	Matériel Diffuseur
	Power Led	Power Led	Power Led
	Minimum distance to be left between the focus of the lighting fixture and the lightened object	Distancia mínima entre el foco de la luminaria y el objeto iluminado	La distance minimum pour être gauche entre le foyer de l'accessoire d'éclairage et l'object allumé
	Five-metre cable	Cable de 5 metros	Câble de 5 mètres
	RGB light	Luz RGB	Lumière RGB
	Halo light direction	Dirección del halo de luz	Direction du faisceau lumineux

General information

Información general

Information générale

Due to the constant evolution of LED technology, those products which contain this light source can vary in their technical characteristics so as to ensure that we can always offer maximum product performance. | The descriptions and dimensions of the items in this catalogue are indicative and may be modified for the purpose of technical or design improvements. | We reserve the right to cancel or change all models without prior notice. | Do not use stronger bulbs than recommended, and always clean lamps with a soft dry cloth alone since metal polish will damage the protective finish. | Energy efficiency labels for all the products in the catalogue can be found at www.leds-c4.com.

All rights reserved. No part of this publication may be reproduced or transmitted in any form or by any means, electronic storage and retrieval system, without permission in writing from the copyright owner(s).

Debido a la constante evolución tecnológica del LED, los productos que incluyen esta fuente de luz pueden experimentar variaciones en sus características técnicas con el objetivo de poder ofrecer siempre las máximas prestaciones en nuestros productos. | Las descripciones y medidas de los aparatos del presente catálogo son orientativas, pudiendo por tanto ser modificadas, a fin de mejorar las características técnicas o de diseño. | La empresa se reserva el derecho de anular o modificar cualquier modelo sin previo aviso. | Para una buena conservación de las lámparas, no usar bombillas de potencia superior a las recomendadas y limpiar simplemente con un paño seco. No usar limpia metales, ya que dañan los barnices protectores que garantizan la duración del acabado. | Las etiquetas de eficiencia energética de todos los productos del catálogo están disponibles en la web www.leds-c4.com.

Todos los derechos reservados. Ninguna parte de este libro puede ser reproducida en ningún formato de papel o electrónico, sin el consentimiento previo del editor o de los propietarios de los derechos.

En raison de l'évolution constante de la technologie LED, les produits dotés de cette source lumineuse peuvent connaître des variations dans leurs caractéristiques techniques, en vue de toujours en optimiser les prestations. | Les descriptions et mesures des appareils de ce catalogue sont données à titre d'orientation, pouvant être modifiées dans le but d'améliorer les caractéristiques techniques ou de design. | L'usine se réserve le droit d'annuler ou modifier l'un ou l'autre de ses modèles sans avis préalable. | Ne pas utiliser d'ampoules d'une puissance supérieure à celle recommandée. Pour un bon entretien, utiliser simplement un chiffon sec. N'utilisez aucun produit pour métaux, ils abîment le vernis protecteur. | Les étiquettes de rendement énergétique pour tous les produits du catalogue sont disponibles sur le site www.leds-c4.com.

Tous droits réservés. Aucune partie de ce livre ne pourra être reproduite en format papier ou électronique sans l'autorisation préalable de l'éditeur ou du propriétaire des droits.



Manufactured according to the set safety and electromagnetism standards of Europe
Fabricado según normas de seguridad y electromagnetismo de Europa
Fabriqués en conformité avec les normes de sécurité et d'électromagnétique de l'Europe

Index

Índice

Index

REF.	PAG.	REF.	PAG.
00-0001-BW-M3	66	00-3685-BW-M1	102
00-0002-BW-M3	66	00-4034-CT-93	91
00-0003-BW-M1	102	00-4348-21-F9	88
00-0053-05-BW	109	00-4348-BW-F9	88
00-0054-05-BW	109	00-4391-BW-03	117
00-0087-N3-F9	127	00-4391-BW-05	117
00-0641-BW-M3	66	00-4409-21-12	97
00-0642-BW-M3	66	00-4416-05-23	125
00-0643-BW-M1	102	00-4416-78-03	125
00-0779-BW-M1	102	00-4601-21-05	123
00-0826-BW-M1	102	00-4601-21-14	123
00-1942-BW-M3	114	00-4607-21-05	123
00-2407-AG-14	129	00-4607-21-14	123
00-2726-AP-05	71	00-4615-21-05	123
00-2726-AQ-78	71	00-4615-21-14	123
00-2727-AP-05	71	00-4872-BW-M3	67
00-2727-AQ-78	71	00-4876-BW-M3	67
00-2872-05-M2	94	00-5275-BW-M1	81
00-2872-06-M2	94	00-5275-CT-M1	81
00-2872-78-M2	94	00-5278-21-21	105
00-2924-BW-M1V1	131	00-5278-BW-BW	105
00-2934-BW-M3V1	67	00-5279-21-37	105
00-2935-BW-M3V1	67	00-5279-BW-37	105
00-3543-BW-BW	111	00-5280-21-21	105
00-3543-F5-F5	111	00-5280-BW-BW	105
00-3642-BW-M3	66	00-5281-21-37	105
00-3643-BW-M3	67	00-5281-BW-37	105
00-3644-BW-M3	67	00-5284-21-21	77
00-3646-BW-M3	66	00-5284-BW-BW	77
00-3647-BW-M3	66	00-5285-21-F1	77
00-3648-BW-M3	66	00-5285-BW-F1	77
00-3649-BW-M3	66	00-5286-21-21	77

REF.	PAG.	REF.	PAG.
00-5286-BW-BW	77	00-6018-27-27	41
00-5287-21-F1	77	00-6019-27-27	41
00-5287-BW-F1	77	00-6020-27-27	41
00-5291-21-21	77	00-6021-27-27	41
00-5291-BW-BW	77	00-6066-27-27	41
00-5457-BW-F9	85	00-6067-27-27	41
00-5457-Z5-F9	85	05-0380-81-B8	183
00-5458-BW-F9	85	05-0380-BW-B8	183
00-5458-Z5-F9	85	05-1817-AF-AF	159
00-5494-BW-BW	105	05-1819-06-06	159
00-5495-BW-37	105	05-1819-27-27	159
00-5496-BW-BW	105	05-1819-AF-AF	159
00-5497-BW-37	105	05-1819-BW-BW	159
00-5498-BW-M1	81	05-1822-06-06V1	159
00-5693-05-05	55	05-1822-27-27V1	159
00-5694-05-05	55	05-1822-AF-AFV1	159
00-5695-05-05	55	05-1822-BW-BWV1	159
00-5696-05-05	55	05-1940-81-81	167
00-5937-CI-CI	121	05-1940-BW-BW	167
00-5938-CI-CI	121	05-1941-81-82	167
00-5939-CI-CI	121	05-1941-BW-82	167
00-5940-CI-CI	121	05-2924-BW-M3	185
00-5958-BW-M1	81	05-3686-21-M1	147
00-5999-05-M1	47	05-4394-78-M1V1	155
00-6000-05-M1	47	05-4394-AH-M1V1	155
00-6001-05-M1	47	05-4409-21-12	177
00-6002-05-M1	47	05-4750-14-F9	181
00-6008-BW-M1	119	05-4787-81-81	167
00-6009-BW-M1	119	05-4787-BW-BW	167
00-6014-06-M1	31	05-5077-06-06V1	171
00-6015-06-M1	31	05-5077-21-21V1	171
00-6017-27-27	41	05-5077-BW-BWV1	171

Index

Índice

Index

280

REF.	PAG.	REF.	PAG.
05-5078-21-21V1	163	10-5076-06-H13W	203
05-5078-BW-BWV1	163	10-5458-BW-F9	211
05-5085-BW-BW	151	10-5458-Z5-F9	211
05-5092-81-B9	189	10-5693-05-05	195
05-5092-BW-B9	189	15-0003-BW-M1	263
05-5093-81-B9	189	15-0056-BW-M1	267
05-5093-BW-B9	189	15-0078-BW-M1	267
05-5276-BW-M1	179	15-1950-BW-M1V1	254
05-5277-BW-M1	179	15-1956-BW-M1V1	254
05-5458-BW-F9	174	15-1959-BW-M1V1	254
05-5458-Z5-F9	174	15-2807-14-M1	265
05-5488-AH-AH	187	15-3231-81-81V1	271
05-5488-BW-BW	187	15-3231-BW-BWV1	271
05-5499-BW-BW	187	15-3536-BW-M1	263
05-5693-05-05	143	15-4601-21-05	259
05-5954-BW-M1	155	15-4601-21-14	259
05-5954-Z5-M1	155	15-4607-21-05	259
05-5956-BW-BW	139	15-4607-21-14	259
05-5957-BW-BW	139	15-4615-21-05	259
05-5968-06-06	171	15-4615-21-14	259
05-5968-21-21	171	15-4785-81-81	271
05-5968-BW-BW	171	15-4785-BW-BW	271
05-5969-AF-AF	159	15-4871-BW-M3	261
05-5969-BW-BW	159	15-4875-BW-M3	261
05-6016-AF-AF	159	15-5099-D9-D9	269
05-6016-BW-BW	159	15-5100-D9-D9	269
10-1824-BW-T002	209	15-5276-BW-M1	257
10-1824-BW-T003	209	15-5277-BW-M1	257
10-1940-05-H13W	207	20-2407-AG-14	129
10-1940-BW-T007	207	25-0057-BW-M1	249
10-3686-21-M1	199	25-0058-BW-M1	249
10-4409-21-12	213	25-1823-BW-T002	233

REF.	PAG.	REF.	PAG.
25-1823-BW-T003	233	PAN-176-BY	166
25-1824-BW-T002	233	PAN-177-14	166
25-1824-BW-T003	233	PAN-177-BY	166
25-1837-05-05	247	PAN-178-14	166
25-1940-05-H13W	230	PAN-178-BY	166
25-1940-BW-T007	230	PAN-179-14	166
25-2407-AG-14	241	PAN-179-BY	166
25-2934-BW-M3	244	PAN-180-14	166
25-3686-21-M1	223	PAN-180-BY	166
25-4035-CT-93	239	PAN-194-AJ	166
25-4409-21-12	236		
25-5076-06-H13W	227		
25-5693-05-05	219		
71-0053-BW-BW	109		
71-1759-BW-BW	233		
71-2232-14-14	94, 125, 127		
71-2241-00-00	102, 263		
71-2934-BW-BW	244		
71-4787-AV-AV	167		
71-6022-27-27	41		
IBIS C/27-81	271		
IBIS C/37-81	271		
IBIS C/37-BW	271		
IBIS C/47-81	271		
IBIS C/47-BW	271		
PAN-157-14	166		
PAN-157-BY	166		
PAN-161-14	166		
PAN-161-BY	166		
PAN-175-14	166		
PAN-175-BY	166		
PAN-176-14	166		

281

Credits Créditos Crédits

Concept, Design and Art Direction

-
Nomon Design

Photography

-
Integrum (Jordi Balcells)

Santi de Pablo
Duccio Malagamba
Jordi Canosa
Jordi Mirallés

Printing

-
Vanguard Grafic

Barcelona, March 2017.

Special thanks to the architects who allowed our products to be temporarily installed in their spaces.

Clément Vergély (p. 178) | Gonçalo Byrne & Barbas-Lopes Arquitectos. (p. 40) | Cruz y Ortiz Arquitectos (p. 28-29, 54) | Eduardo Pesquera & Jesús Ulargui & Eduardo Fdez.-Abascal & Floren Muruzábal & Alberto Alonso & Joaquín Barrientos (p. 137) | b720-Fermín Vázquez Arquitectos (p. 170).

Concepto, Diseño y Dirección de arte

-
Nomon Design

Fotografía

-
Integrum (Jordi Balcells)

Santi de Pablo
Duccio Malagamba
Jordi Canosa
Jordi Mirallés

Impresión

-
Vanguard Grafic

Barcelona, Marzo 2017.

Agradecimientos especiales a los arquitectos que han permitido instalar de manera temporal nuestros productos en sus espacios.

Clément Vergély (p. 178) | Gonçalo Byrne & Barbas-Lopes Arquitectos. (p. 40) | Cruz y Ortiz Arquitectos (p. 28-29, 54) | Eduardo Pesquera & Jesús Ulargui & Eduardo Fdez.-Abascal & Floren Muruzábal & Alberto Alonso & Joaquín Barrientos (p. 137) | b720-Fermín Vázquez Arquitectos (p. 170).

Concept, Maquette et direction artistique

-
Nomon Design

Photographie

-
Integrum (Jordi Balcells)

Santi de Pablo
Duccio Malagamba
Jordi Canosa
Jordi Mirallés

Impression

-
Vanguard Grafic

Barcelone, Mars 2017.

Tous nos remerciements aux architectes qui ont permis l'installation temporaire de nos produits dans leurs espaces.

Clément Vergély (p. 178) | Gonçalo Byrne & Barbas-Lopes Arquitectos. (p. 40) | Cruz y Ortiz Arquitectos (p. 28-29, 54) | Eduardo Pesquera & Jesús Ulargui & Eduardo Fdez.-Abascal & Floren Muruzábal & Alberto Alonso & Joaquín Barrientos (p. 137) | b720-Fermín Vázquez Arquitectos (p. 170).

Close to you

Headquarters

-

LEDS-C4, S.A.

Afores sn, 25750 Torà | Lleida | Spain

+34 973 468 100

leds-c4@leds-c4.com

Customer Service Department

España

-

+34 973 468 101

spain@leds-c4.com

UK

-

0808 234 2641

uk@leds-c4.com

France

-

+34 973 468 130

france@leds-c4.com

Germany

-

0800 188 0989

Italia

-

800 784 275

italia@leds-c4.com

Portugal

-

+34 973 468 130

portugal@leds-c4.com

Local Offices

Middle east countries

-

LEDS-C4 LIGHTING DMCC

Fortune Executive Tower – JLT

PO 336910 – DUBAI – UAE

+971 4458 4272

middleeast@leds-c4dubai.com

Poland

-

LEDS-POLSKA sp. z o.o.

ul.Nektarowa 11B 52-210.

Wroclaw – POLAND

+48 71 733 64 01

biuro@leds-polska.pl

Asia Pacific

-

LEDS-C4,S.A.

59 New Bridge Road

059405 SINGAPORE

+65 6532 2119

asiapacific@leds-c4.com

